

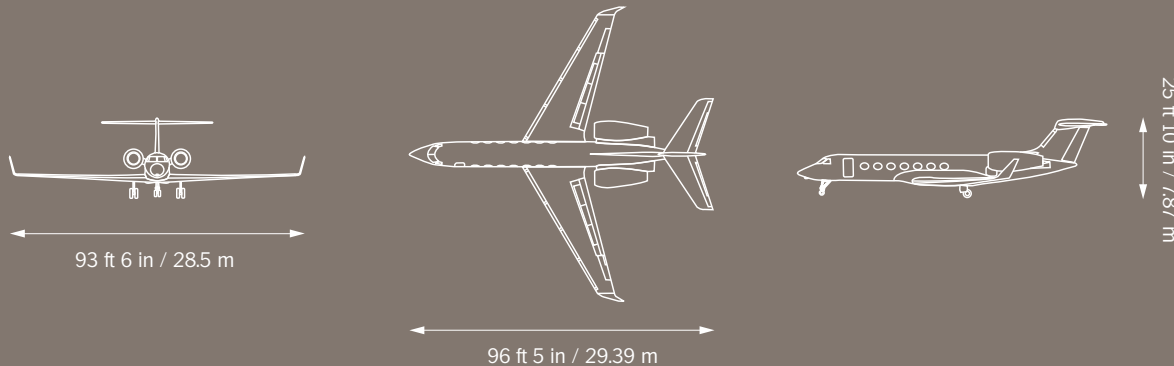

Gulfstream® **G550**® *Large Cabin, Ultra-Long Range*

G550



Gulfstream®
A GENERAL DYNAMICS COMPANY

For more information, visit www.gulfstream.com or call 1 (800) 810-GULF (4853).

© 2008 Gulfstream Aerospace Corporation 11.08.7M · 08-08508-REV1

PERFORMANCE

*Maximum Range	6,750 nm / 12,501km
(Mach 0.80, 8 passengers, 4 crew and NBAA IFR reserves)	
Normal Cruise	Mach 0.80 / 459 ktas / 850 km/h
High Speed Cruise	Mach 0.87 / 500 ktas / 926 km/h
Mmo (Maximum Operating Mach Number)	Mach 0.885
Takeoff Distance (SL, ISA, MTOW)	5,910 ft / 1,801 m
Landing Distance (SL, ISA, MLW)	2,770 ft / 844 m
Initial Cruise Altitude	41,000 ft / 12,497 m
Maximum Cruise Altitude	51,000 ft / 15,545 m

WEIGHTS

Maximum Takeoff Weight	91,000 lb / 41,277 kg
Maximum Landing Weight	75,300 lb / 34,156 kg
Maximum Zero Fuel Weight	54,500 lb / 24,721 kg
**Basic Operating Weight (including 4 crew)	48,300 lb / 21,909 kg
**Maximum Payload	6,200 lb / 2,812 kg
**Payload with Maximum Fuel	1,800 lb / 816 kg
Maximum Fuel Weight	41,300 lb / 18,733 kg

DESIGN STANDARDS

Avionics	Gulfstream PlaneView®
Engines (2)	Rolls-Royce BR710 C4-11
Rated Takeoff Thrust (each)	15,385 lb / 68.4 kN
Passengers: Maximum	19
Typical Outfitting	14 - 18

INTERIOR

Cabin Length	50 ft 1 in / 15.27 m
Cabin Height	6 ft 2 in / 1.88 m
Cabin Width	7 ft 4 in / 2.24 m
Cabin Volume	1,669 cu ft / 47.26 cu m
Baggage Compartment Volume	226 cu ft / 6.40 cu m

COMFORT

Window	14 Gulfstream Signature Oval Windows
Galley	Forward or Aft Galley
Lavatories	Forward and Aft Lavatory
Cabin Configurations	12 Select Floorplans or Tailored Floorplans

* NBAA IFR theoretical range. Actual range will be affected by ATC routing, operating speed, weather, outfitting options and other factors.

** Stated weights are based on theoretical standard outfitting configurations. Actual weights will be affected by outfitting options and other factors.