

**Bell**  
**407**

**Bell**  
**Helicopter**  
A Textron Company



**SPECIFICATIONS**



**PRODUCT SPECIFICATIONS**  
**JANUARY 2006**

**For additional information visit the Bell Helicopter Textron Website**

Homepage: [www.bellhelicopter.com](http://www.bellhelicopter.com)

**BELL HELICOPTER TEXTRON INC.**

**Sales Contact Telephone Numbers**

Sales Inquiries

U.S. Toll Free: 1-800-FLY-BELL

International/US: 817-280-2800

Email: [marketing@bellhelicopter.textron.com](mailto:marketing@bellhelicopter.textron.com)

**Regional Sales Areas**

US/Canada 817-280-6789

Asia Pacific 817-280-2197

Europe/Middle East/Africa 817-280-3261

Latin America 817-280-2879

Used Helicopter Sales / [www.BellNetX.com](http://www.BellNetX.com) 817-280-2147

Fax: 817-280-8802

**Customer Center**

**Ft. Worth / Alliance Airport Facility**

P. O. Box 482

Ft. Worth, TX 76101-0482

817-280-6187 Fax: 817-280-8802

[marketing@bellhelicopter.textron.com](mailto:marketing@bellhelicopter.textron.com)

**Manufacturing Facility**

Bell Helicopter Textron Canada Limited

12,800 rue de l'Avenir

Mirabel, Quebec

Canada J7J 1R4

450-437-3400 Fax: 450-437-2006

This book was produced by



Visual Communications Center

P. O. Box 482

Ft. Worth, TX 76101-0482



## PUBLISHERS NOTICE

The data presented in this document is general in nature, and has been compiled from Bell Helicopter Textron, Inc. [BHTI] source materials including but not limited to; The Approved Rotorcraft Flight Manual, Maintenance Manual, Illustrated Parts Catalog, and other engineering design specifications.

This document is intended for the use of **BHTI Sales Personnel** and for **prospective customers** as an aid in determining estimated weight and performance of the helicopter when configured with equipment for specific missions.

Disclosure, reproduction, or use of any material in this document by persons other than BHTI employees, and BHTI independent representatives [International Dealers] is **forbidden** without written permission from Bell Helicopter Textron.

The listings of Optional Equipment [KITS] are subject to revision and change, and also may be different for specific serial number helicopters or special custom configurations. Please consult the *NOTES* found in the right margins of the optional equipment list pages for **equipment compatibility**. The continuing product improvement process of BHTI may cause some components, equipment, and compatibility to be changed or replaced.

The SPECIFICATIONS, WEIGHTS, DIMENSIONS, AND PERFORMANCE DATA shown in this document are subject to change without notice.



## EXTERIOR DIMENSIONS

### STANDARD LOW SKID GEAR

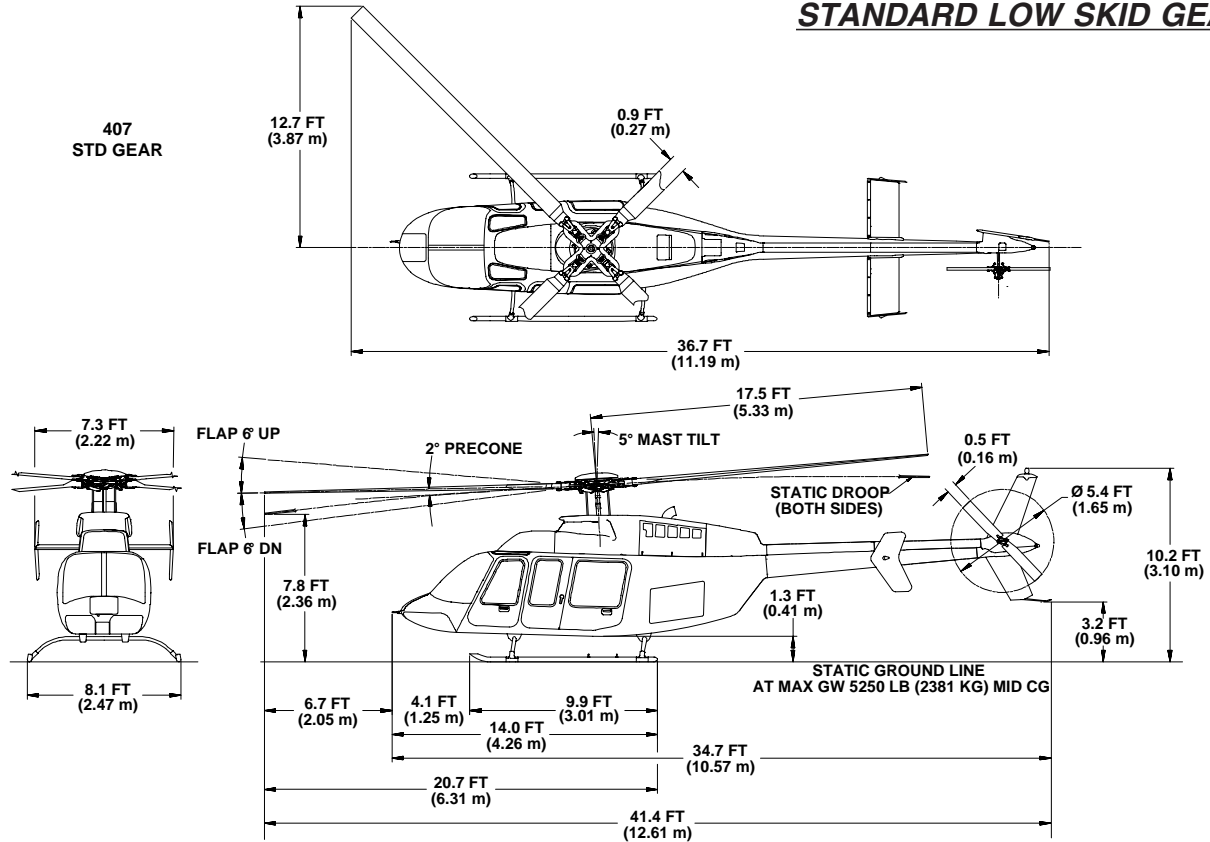

### OPTIONAL HIGH SKID GEAR w/AAI FLIGHTSTEP®

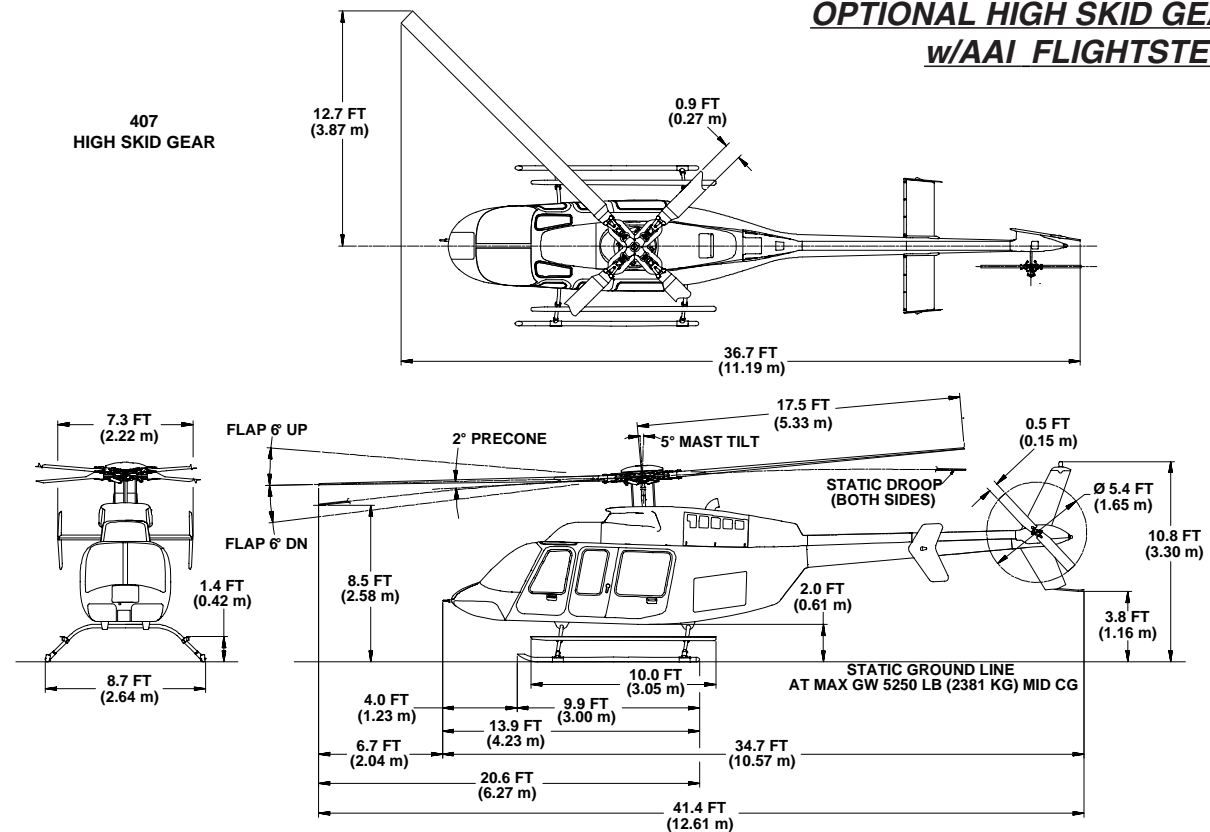

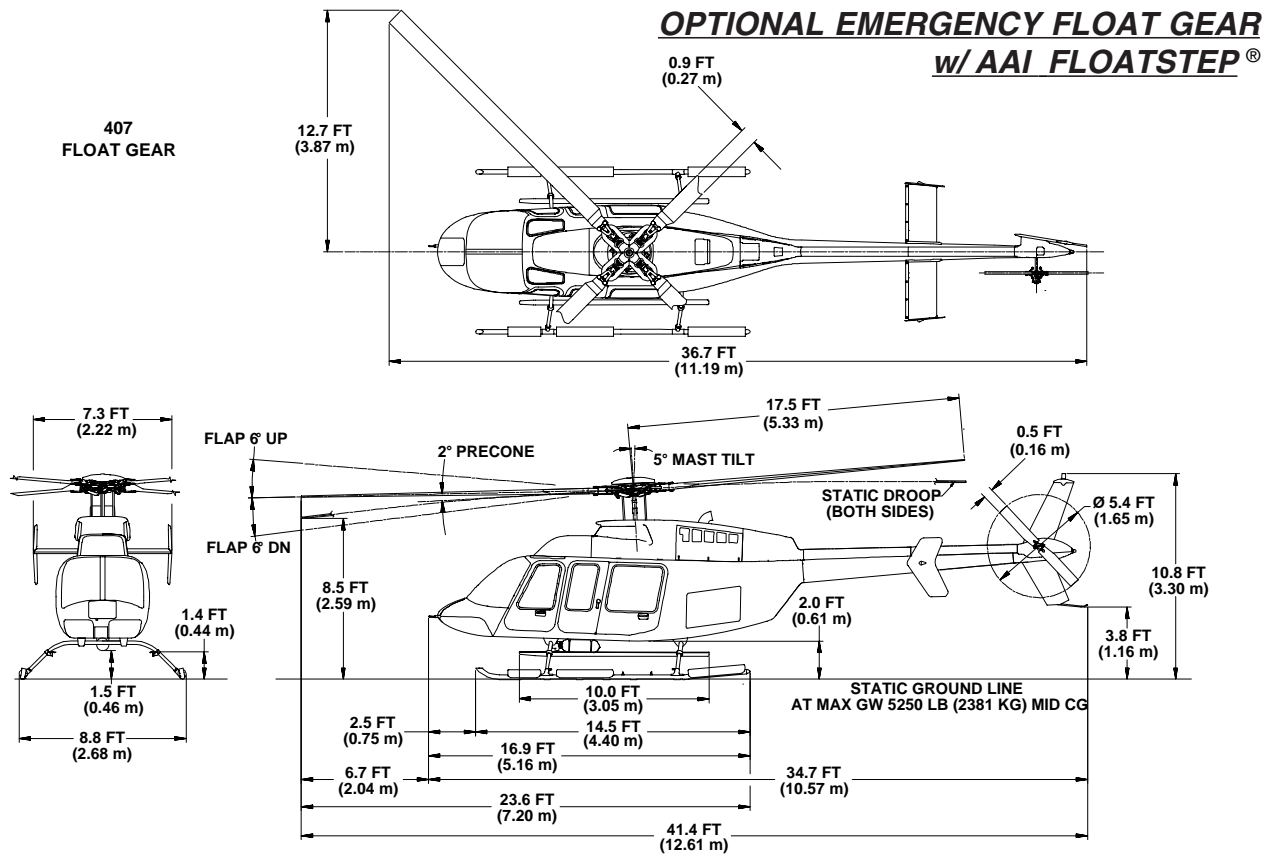

**OPTIONAL BLADE FOLDING KIT DIMENSIONS**

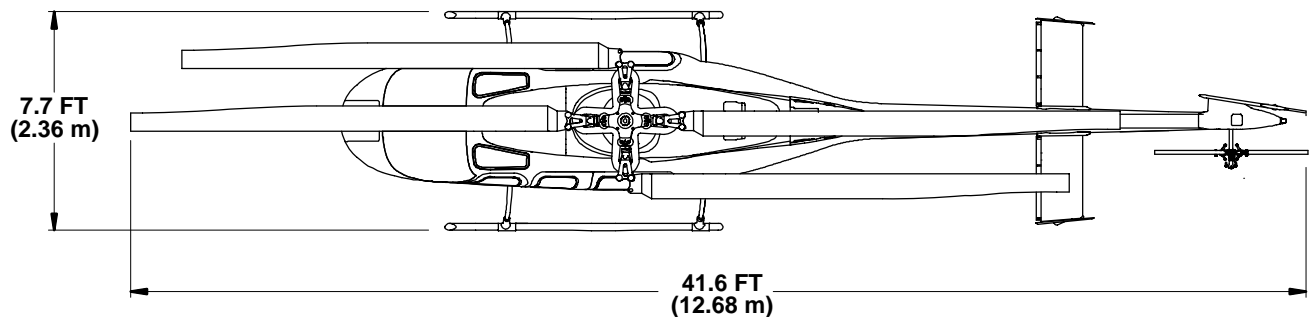

**MINIMUM HANGAR SIZE\***

**ROTOR NOT FOLDED**

25.1 FT X 36.6 FT  
[ 7.7 M X 11.2 M ]

**MINIMUM HANGAR SIZE\***

**ROTOR FOLDED**

7.7 FT X 41.6 FT  
[ 2.4 M X 12.7 M ]

\*ALLOWANCE SHOULD BE MADE FOR HIGH SKID GEAR, GROUND WHEELS, EMPTY FUEL CONDITION, AND DOOR LIP WHEN CONSIDERING HANGAR DOOR WIDTH AND HEIGHT



## INTERNAL DIMENSIONS [APPROXIMATE]

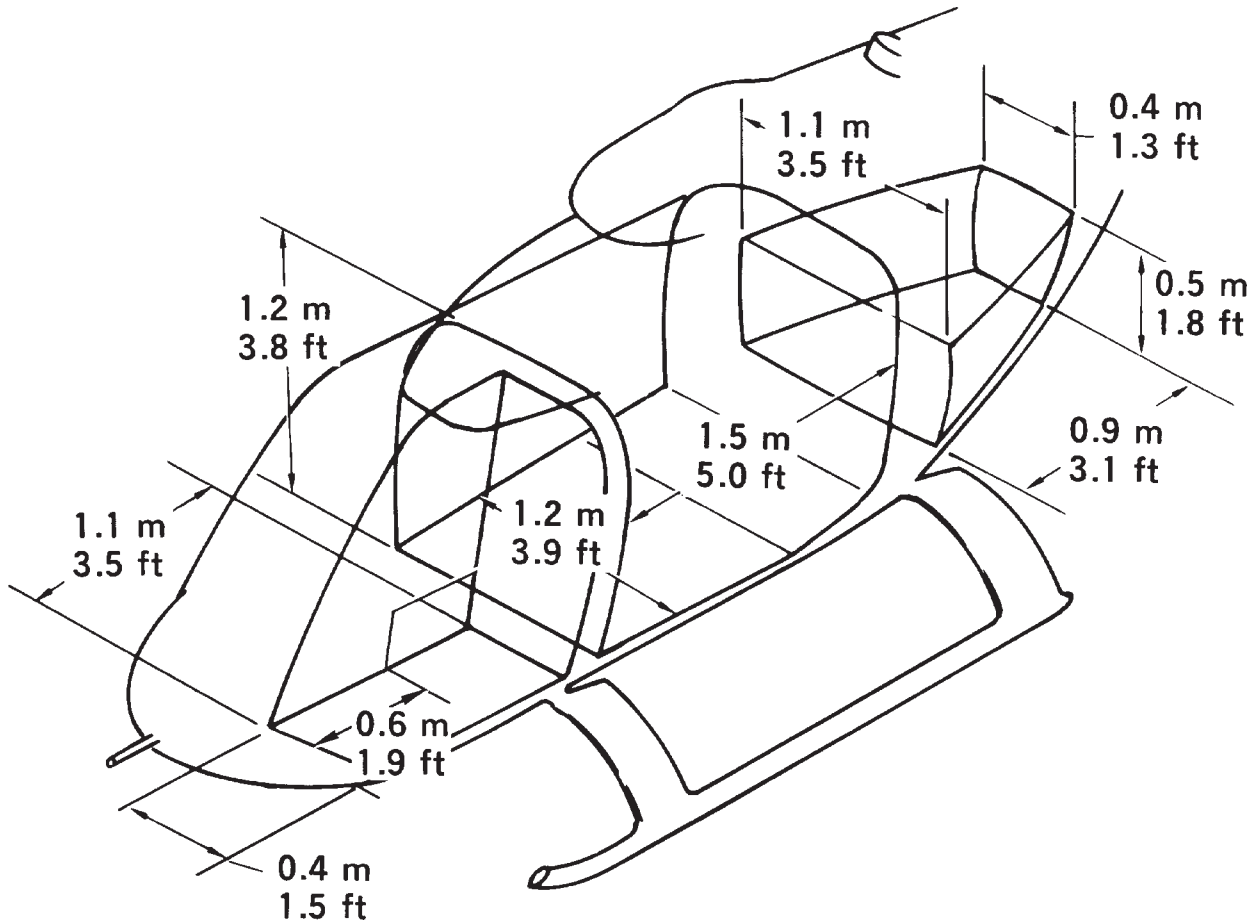

**Approximate cargo space:**

**Aft Cabin-2.4 cubic meters (85 cubic feet)**

**Left front-0.6 cubic meters (20 cubic feet)**

**Baggage compartment-0.45 cubic meters  
(16 cubic feet)**

**Floor loading:**

**Cabin-3.7 kg/sq. meter (75 lb/ sq. foot)**

**Baggage-4.2 kg/sq. meter (86 lb/sq. foot)**

**Max Baggage weight-113 kg (250 pounds)**



INTENTIONALLY LEFT BLANK



## SPECIFICATION SUMMARY (U. S. Units)

<u>WEIGHTS</u>	<i>(Serial No. 53633 &amp; Subsequent)</i>	<u>LBS</u>
Standard Configuration Weight (Note 1)		2668
Internal Gross Weight [Normal / Optional]( <i>*Note 2</i> )		5000 / 5250*
External Load Gross Weight		6000
Useful Load [Gross Wt - Standard Configuration Wt] {Normal / Optional}( <i>*Note 2</i> )		2332/ 2582*
Maximum External Load [Cargo Hook Limit]		2646

**Note 1: The Standard Configuration Weight includes 7-place upholstered interior with individual seat belts, carpeting, and soundproofing material. Ballast is not included since it is a function of installed optional equipment. 13 pounds of oil is included.**

## PERFORMANCE SUMMARY (International Standard Day Except as Noted)

• • • REFER TO DEMONSTRATED TAKEOFF & LANDING AND MAXIMUM OPERATING ALTITUDE NOTES ON THE PERFORMANCE CHARTS • • •

<u>TAKEOFF, GROSS WEIGHT</u>		<u>LBS</u>	<u>4000</u>	<u>4500</u>	<u>5000</u>	<u>5250</u>
IGE Hovering Ceiling (4.5 ft Skid Height)	ISA	ft	19,200	15,600	12,200	5400*
	ISA+20C	ft	15,600	11,700	7900	3150*
	ISA+30C	ft	13,250	8850	4600	2050*
OGE Hovering Ceiling	ISA	ft	17,600	13,850	10,450	5400*
	ISA+20C	ft	13,800	9650	5750	3150*
	ISA+30C	ft	11,050	6500	1850	(5200lb@SL)*
Service Ceiling @ MCP (100 ft/min)	ISA	ft	20,000+	20,000+	17,600	16,050
	ISA+20C	ft	20,000+	17,750	14,300	12,650
<b>Cruise at Long Range Cruise Speed (LRC)</b>						
Range [standard fuel]	SL, ISA	nm	342	336	330	326
LRC Speed		kn	120	120	121	121
Range [standard fuel]	4000 ft, ISA	nm	383	375	364	357
LRC Speed		kn	118	120	120	120
Maximum Cruise Speed @ Takeoff Gross Weight	SL, ISA	kn	136	135	133	132
	SL, ISA+20C	kn	130	129	126	125
	4000 ft, ISA	kn	140	138	135	133
	4000 ft, ISA+20C	kn	133	130	126	123
Endurance @ Loiter 60 kn	SL, ISA	hr	4.0	3.9	3.8	3.7
	4000 ft, ISA	hr	4.5	4.4	4.2	4.1

**Note 2: Operation at Internal Gross Weight above 5000 pounds / 2381 Kilograms requires the Optional Increased Internal Gross Weight Kit (Performance data shown on Page 19).**

### ENGINE RATING:

Rolls-Royce 250-C47B with Full Authority Digital Electronic Control:

Takeoff Horsepower(Uninstalled Thermodynamic Capability)	SHP	813
(Mechanical Limit)	SHP	674
Maximum Continuous(Uninstalled Thermodynamic Capability)	SHP	701
(Mechanical Limit)	SHP	630

### TRANSMISSION RATING (Engine Output):

Takeoff Horsepower (5 minutes)	SHP	674
Maximum Continuous	SHP	630

### FUEL CAPACITY (USABLE):

Standard	127.8 US Gallons
Auxiliary(Optional)	19 US Gallons

THE DATA SET FORTH ON THIS DOCUMENT ARE GENERAL IN NATURE AND MAY VARY WITH CONDITIONS. FOR PERFORMANCE DATA AND OPERATING LIMITATIONS FOR ANY SPECIFIC FLIGHT MISSION, REFERENCE MUST BE MADE TO THE APPROVED FLIGHT MANUAL.



## SPECIFICATION SUMMARY (Metric Units)

<u>WEIGHTS</u>	(Serial No. 53633 & Subsequent)	<u>Kg</u>
Standard Configuration Weight (Note 1)		1210
Internal Gross Weight [Normal / Optional](*Note 2)		2268 / 2381*
External Load Gross Weight		2722
Useful Load [Gross Wt - Standard Configuration Wt] {Normal / Optional}(*Note 2)		1058/ 1171*
Maximum External Load [Cargo Hook Limit]		1200

Note 1: The Standard Configuration Weight includes 7-place upholstered interior with individual seat belts, carpeting, and soundproofing material. Ballast is not included since it is a function of installed optional equipment. 6 kilograms of oil is included.

## PERFORMANCE SUMMARY (International Standard Day Except as Noted)

• • • REFER TO DEMONSTRATED TAKEOFF & LANDING AND MAXIMUM OPERATING ALTITUDE NOTES ON THE PERFORMANCE CHARTS • • •

<u>TAKEOFF, GROSS WEIGHT</u>		<u>KG</u>	<u>1814</u>	<u>2041</u>	<u>2268</u>	<u>2381</u>
IGE Hovering Ceiling (1.4 M Skid Height)	ISA	m	5852	4755	3718	1646*
	ISA+20C	m	4755	3566	2408	960*
	ISA+30C	m	4039	2697	1402	625*
OGE Hovering Ceiling	ISA	m	5364	4221	3185	1646*
	ISA+20C	m	4206	2941	1753	960*
	ISA+30C	m	3368	1981	564	(2358kg@SL)*
Service Ceiling @ MCP (0.5 m/s)	ISA	m	6096+	6096+	5364	4892
	ISA+20C	m	6096+	5410	4359	3856
<b>Cruise at Long Range Cruise Speed (LRC)</b>						
Range [standard fuel]	SL, ISA	km	634	623	612	604
LRC Speed		km/h	222	222	224	224
Range [standard fuel]	1200m, ISA	km	710	695	675	661
LRC Speed		km/h	219	222	222	222
Maximum Cruise Speed	SL, ISA	km/h	250	250	246	244
@ Takeoff Gross Weight	SL, ISA+20C	km/h	241	239	234	231
	1200m, ISA	km/h	259	256	250	246
	1200m, ISA+20C	km/h	246	241	234	228
Endurance@ Loiter 111 km/h	SL, ISA	hr	4.0	3.9	3.8	3.7
	1200m, ISA	hr	4.5	4.4	4.2	4.1

Note 2: Operation at Internal Gross Weight above 5000 pounds / 2381 Kilograms requires the Optional Increased Internal Gross Weight Kit (Performance data shown on Page 19).

### ENGINE RATING:

Rolls-Royce 250-C47B with Full Authority Digital Electronic Control:

Takeoff Horsepower(Uninstalled Thermodynamic Capability)	kW	606
(Mechanical Limit)	kW	503
Maximum Continuous(Uninstalled Thermodynamic Capability)	kW	523
(Mechanical Limit)	kW	470

### TRANSMISSION RATING (Engine Output):

Takeoff Horsepower (5 minutes)	kW	503
Maximum Continuous	kW	470

### FUEL CAPACITY (USABLE):

Standard	484 Liters
Auxiliary(Optional)	72 Liters

THE DATA SET FORTH ON THIS DOCUMENT ARE GENERAL IN NATURE AND MAY VARY WITH CONDITIONS. FOR PERFORMANCE DATA AND OPERATING LIMITATIONS FOR ANY SPECIFIC FLIGHT MISSION, REFERENCE MUST BE MADE TO THE APPROVED FLIGHT MANUAL.



## **407 SEATING**

**CREW SEATING** - Two individual ergonomically designed seats with adjustable lumbar support, each equipped with seat belt, double strap shoulder harness and inertia reel, are located in the cockpit. The color and upholstery material for the seats, and interior trim of the cockpit match that which is selected for the cabin. The seat belts are black.

## **STANDARD SEATING & INTERIOR TRIM**



**STANDARD SEATING & INTERIOR TRIM** - The standard cabin seating consists of **five** ergonomically designed seats with individual seat belts and single strap shoulder harness, arranged with three equal width forward facing seats across the rear of the cabin and two individual rearward facing seats aft of the cockpit. Available with Grey, Blue, Red, or Tan upholstery fabric with Black seat belts. All vinyl or vinyl surround / fabric insert upholstery is available as an extra cost option. **The standard interior trim** consists of full plastic closeouts on all airframe areas, vinyl covered arm rests, and molded plastic outboard headliners. The floor is covered in low loop blend carpet. The standard seating and interior trim are included in the basic aircraft weight.

***Specifications subject to change without notice.***

## **SEATING** (continued);

### **CORPORATE SEATING & INTERIOR TRIM**

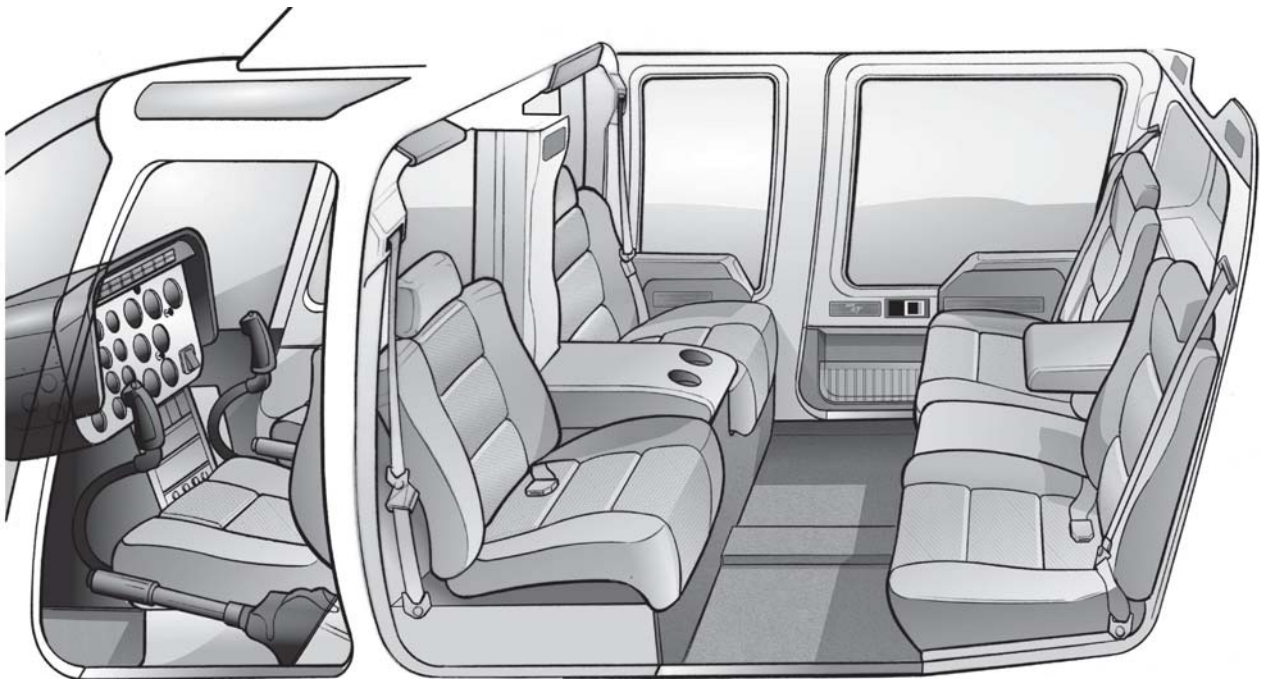

**CORPORATE SEATING & INTERIOR TRIM** - The corporate cabin seating consists of **five** 'Overstuffed Style' seats with individual seat belts and single strap shoulder harness, arranged with two extra wide forward facing **outboard** seats and a **middle** seat for occasional use across the rear of the cabin (with a fold down arm rest between the outboard seats) and two individual rearward facing seats aft of the cockpit. Available with Pewter, Mushroom, Dark Blue, Saddle, Burgundy, Smoke Grey, and Forest Green upholstery with color coordinated seat belts (Crew seat belts are black). Seats can be all fabric (basic ship), optional leather with fabric inserts or all leather with perforated leather inserts. **The corporate interior trim** consists of full plastic closeouts on all airframe areas, fabric covered outboard headliner blankets, and armrests covered with color coordinated leather. Carpet is 100% wool cut pile. Selection of the corporate interior trim also specifies installation of **Corporate Soundproofing**, which provides a reduced interior noise level. The corporate seating and interior trim (and corporate soundproofing) **increase** the basic aircraft empty weight **9 lbs. (4.1 kg.)**.

**Specifications subject to change without notice.**



## **Standard Configuration** **(Items Included in List Price)**

### **AIRFRAME**

*Cabin; bonded aluminum honeycomb, and semi-monocoque structure with composite side panels and aft fuselage skins*

*Doors (five), one hinged double door & copilot door on left side, pilot & passengers on right side, all doors are composite material*

*Landing gear, tubular skid type with replaceable skid shoes*

*Locks for cabin doors and luggage compartment*

*Luggage compartment (16 cu ft, 250 lbs capacity), with composite door*

*Provisions for mooring, jacking and single point lifting*

*Tail boom, monocoque structure with vertical fin and fixed stabilizer*

*Tail skid (tail rotor guard)*

*Windows (except windshield), gray tinted plexi-glass [sliding panels in doors are available as a no-cost option]*

*Three color exterior paint schemes*

*Standard paint schemes A, B, and C, as shown on paint selector page at rear of this book.*

*Custom paint schemes are quoted on request.*

### **INTERIOR**

*7-place interior with soundproofing, carpeting, and data case. Color options available for upholstery and carpet*

*7-place shoulder harnesses, dual straps in cockpit, single strap in cabin*

*Fire extinguisher, cabin*

*First aid kit*

*Parcel shelf (behind aft seat)*

*Ram air ventilation system*

*Storage area behind pilot & copilot seats*

### **POWERPLANT**

*Rolls-Royce Model 250-C47B gas turboshaft engine with FADEC and Direct Reversion to Manual Governor*

*Fuel pump, engine driven*

*Fuel pumps (4 canister type) w/ 2 boost pumps submerged in main tank, and 2 transfer pumps in the forward fuel tanks*

*Fuel system, 127.8 gal [484 liter] usable capacity*

*Oil system, 1.5 gal [5.7 liter] capacity, with sight glass*

*Compressor wash provisions*

*Engine mounted 10-micron oil filter*

*Airframe Fuel Filter [eliminates requirement for PRIST]*

### **ROTORS AND CONTROLS**

*Main rotor, soft in plane flex beam hub with four fiberglass blades, CHOICE of STANDARD [black top-white bottom] or HIGH VISIBILITY [orange/white top-white bottom] painted rotor blades*

*Tail rotor; two fiberglass blades, semirigid*

*Hydraulic boost system for Main & Tail Rotor (separate pump and reservoir)*

*Mechanical flight control linkages throughout*

*Airspeed Activated Pedal Stop [AAPS] with built in test function, electrical override release switch, and manual override release*

### **TRANSMISSION DRIVE SYSTEM**

*Soft mounted pylon isolation system*

*Freewheeling unit (between engine and main transmission)*

*Kaflex input drive shaft*

*Gearbox, tail rotor, 90° reduction*

*Main transmission*

*Oil cooler*

*Oil filter with replaceable type cartridge*

*Oil pump, constant pressure*

**Specifications subject to change without notice.**



## Standard Configuration (continued)

### FLIGHT AND ENGINE INSTRUMENTS

Clock, digital w/ OAT & Volt Meter  
Compass, magnetic  
Dual tachometer (rotor and engine)  
Inclinometer  
Indicator, airspeed  
Indicator, altimeter  
Indicator, IVSI  
Indicator LCD, engine oil pressure / temperature  
Indicator LCD, fuel quantity with forward cell quantity switch  
Indicator LCD, fuel pressure / generator load meter  
Indicator LCD, NG speed \*<sub>w/ EXCEEDANCE MONITORING</sub>  
Indicator LCD, Torque \*<sub>w/ EXCEEDANCE MONITORING</sub>  
Indicator LCD, transmission oil pressure / temperature  
Indicator LCD, T. O. T. \*<sub>w/ EXCEEDANCE MONITORING</sub>  
Hour meter (located in battery compartment)  
Maintenance download ports (FADEC & LCD instruments)

### MONITORING SYSTEM

Caution indication lights:  
Auto relight  
Baggage door  
Battery hot  
Battery relay  
Check instruments  
Cyclic Centering  
Engine anti-ice  
Engine chip detector  
Engine out and low rotor RPM warning lights and horn with mute switch. (Low RPM or engine out)  
Engine overspeed  
Fuel boost pump inoperative, left & right  
Fuel transfer pump inoperative, left & right  
Fuel filter bypass indicator  
Fuel valve in transit  
Fuel low  
Fadec fault  
Fadec fail  
Pedal Stop

Fadec degraded  
Fadec manual  
Generator failure  
Hydraulic system  
Litter door  
Restart Fault  
Start  
Tail rotor gearbox chip detector  
Transmission oil pressure  
Transmission oil temperature  
Transmission (& Freewheeling unit) chip detector

### ELECTRICAL

28 volt DC system  
Battery, 17 amp-hr nickel cadmium  
External power and grounding receptacle  
Lights:  
Anticollision strobe  
Cockpit/map  
Instrument  
Aft cabin  
Landing (two 250 watt)  
Position  
Starter-generator (180 ampere)  
Solid state voltage regulator  
28 volt outlet in cabin  
Heated pitot tube & Static ports

### MISCELLANEOUS

Covers, engine inlet and exhaust stack  
Cover pitot tube  
Flight bag  
Ground handling wheels with lift tube  
Operating manuals:  
Aircraft log book  
Engine log book  
Engine operating & maintenance manual  
Engine parts manual  
Flight manual  
Illustrated parts catalog  
Maintenance and overhaul manual  
Tiedown assemblies, main rotor and tail rotor

**Specifications subject to change without notice.**



**Optional Accessories**  
**[ BHT Manufactured Kits ]**

\*\*\*\*\* REFER TO NOTES FOR KIT COMPATIBILITY \*\*\*\*\*

**ADDITIONAL KITS & STC ITEMS MAY BE AVAILABLE FOR FACTORY INSTALLATION. PLEASE CONSULT SALES OR CONTRACT PERSONNEL REGARDING SPECIAL NEEDS PRIOR TO SELECTION OF FINAL CONFIGURATION.**

Kit Description	Wt (lbs)	Wt (Kg)	Notes
<b>AIRFRAME</b>			
HIGH SKID GEAR with FLIGHTSTEPS	32.1	14.6	(1, 2)
EMERGENCY POPOUT FLOATS (LANDING GEAR)	83.8	38.0	(1, 3, 18)
EMERGENCY POPOUT FLOATS (FLOTATION KIT)	88.9	40.3	(18)
EMERGENCY POPOUT FLOATS (RESERVOIR KIT)	68.7	31.2	(18)
SKID GEAR FAIRINGS for LOW SKID ONLY	11.9	5.4	
AUX. FUEL TANK PROVISIONS (19 GAL)	5.0	2.3	
AUX. FUEL TANK EQUIPMENT (19 GAL)	29.6	13.4	
DUAL CONTROLS	11.3	5.1	
<b>AUDIO</b>			
AFT AUDIO ICS - 3 STATION with 3 HEADSETS & DROP CORDS	8.6	3.9	
AFT AUDIO ICS - 5 STATION with 5 HEADSETS & DROP CORDS	13.5	6.1	
<b>AVIONICS</b>			
VHF EQUIPMENT (KX-155) for OMNI w/KI-208 ONLY	8.1	3.7	(4)
VHF EQUIPMENT (KX-165) for ANY KCS-55A w/HIS KI-525A	8.8	4.0	(4)
ADF EQUIPMENT (KR-87)	6.3	2.9	(4)
TRANSPONDER PROVISIONS (KT-76A) MODE C	0.9	0.4	(5)
TRANSPONDER EQUIPMENT (KT-76A) MODE C	2.5	1.1	(5)
TRANSPONDER PROVISIONS (DIGITAL) (KT-70)	0.7	0.3	(5)
TRANSPONDER EQUIPMENT (DIGITAL) (KT-70)	3.8	1.7	(5)
GPS PROVISIONS (KLN-89B)	4.4	2.0	
GPS EQUIPMENT (KLN-89B w/KA33 BLOWER)	5.3	2.4	(5, 6)
OMNI w/CDI KI208 for KX-155 ONLY	3.6	1.6	
COMM#2 KY196A EQUIPMENT	3.4	1.5	
AVIONICS MASTER SWITCH (standalone-NO ENC. ALT.)	1.4	0.6	
COMM#2 KY196A PROVISIONS	1.7	0.8	
VHF/ADF PROVISIONS w/AUDIO PANEL ( KMA24H-71 )	9.1	4.1	
COMPASS SYSTEM KCS-55A PROVISIONS w/KI-525A	3.9	1.8	
COMPASS SYSTEM KCS-55A EQUIPMENT w/KI-525A	7.6	3.4	(7)
COMPASS SYSTEM KCS-55A PROV w/KI-525A (GPS COMPAT.)	4.9	2.2	
COMPASS SYSTEM KCS-55A EQIP W/ KI-525A (GPS COMPAT.)	8.3	3.8	(7, 8)
ENCODING ALTIMETER w/AVIONICS MASTER SWITCH	2.3	1.0	(1, 5)
TURN & SLIP / ATTITUDE INDICATOR	3.7	1.7	
DIRECTIONAL GYRO	4.5	2.0	(7)
ELT POINTER 4000 W/3001 WHIP ANTENNA	3.9	1.8	
ADF ANTENNA RELOCATION	-2.0	-0.9	(4)
VHF ANTENNA RELOCATION	3.0	1.4	(4)
C. I. S. [Russian] CERTIFICATION PROVISIONS	1.2	0.5	(9)
<b>ENGINE</b>			
PARTICLE SEPARATOR WITH BLEED AIR NETWORK	17.0	7.7	(1, 10)
ENGINE FIRE DETECTION	2.0	0.9	
QUIET CRUISE	1.5	0.7	
5250 POUND GROSS WEIGHT OPTION	0.0	0.0	

**Specifications subject to change without notice.**



**Optional Accessories (continued)**  
**[ BHT Manufactured Kits ]**

..... REFER TO NOTES FOR KIT COMPATIBILITY .....

Kit Description	Wt (lbs)	Wt (Kg)	Notes
<b>EQUIPMENT</b>			
SNOW BAFFLE	5.2	2.4	
EXPANDABLE BLADE BOLTS (2 EACH)	1.5	0.7 (1)	
CARGO HOOK EQUIPMENT	16.7	7.6	
CARGO HOOK PROVISIONS	4.2	1.9	
ROTOR BRAKE	5.5	2.5	
CARGO RESTRAINT INTERNAL PROVISIONS	1.9	0.9	
28 AMPS HOUR BATTERY	24.9	11.3	
COCKPIT STORAGE KIT	1.4	0.6	
LITTER EQUIPMENT (ONE)	22.0	10.0 (11)	
SKI PROVISIONS (for Single Litter ONLY)	1.5	0.7 (11)	
LITTER PROVISIONS for Single Litter	5.7	2.6	
<b>INTERIOR</b>			
INTERIOR, CORPORATE	7.3	3.3 (1, 12)	
SOUND-PROOFING, CORPORATE	8.2	3.7 (1, 12)	
STANDARD HEADLINER with A/C DUCTS	4.7	2.1 (1)	
ARM RESTS, CORPORATE (pair)	0.3	0.1 (1, 12)	
CORPORATE SEATS	7.7	3.5 (1)	
WINDOWS, SLIDING PASSENGER	2.5	1.1 (1)	
<b>PAINT</b>			
MARKINGS FOR HIGH VISIBILITY M/R BLADES (WHITE & ORANGE)	0.0	0.0 (14)	
<b>Credits</b>			
<b>EQUIPMENT</b>			
GROUND HANDLING WHEELS	95.0	43.1	
<b>PAINT</b>			
NO EXTERIOR PAINT	-16.7	-7.6	
WHITE PAINT ONLY	0.0	0.0	



## **Optional Accessories [VENDOR KITS] (continued)**

• • • • • REFER TO NOTES FOR KIT COMPATIBILITY • • • • •

<b>Kit Description</b>	<b>Wt (lbs)</b>	<b>Wt (Kg)</b>	<b>Notes</b>
<b>STC's</b>			
<b>AIRFRAME</b>			
DOOR OPENERS CREW	2.8	1.3	
DOOR OPENERS PASSENGER	2.8	1.3	
DOOR OPENERS BAGGAGE	1.0	0.5	
STEP / HANDLE (ONE STEP)	1.0	0.5	
MAINTENANCE STEP FOLDING L/H	2.0	0.9	
MAINTENANCE STEP FOLDING R/H	2.0	0.9	
MAINTENANCE STEP FIXED L/H	2.0	0.9	
MAINTENANCE STEP FIXED R/H	2.0	0.9	
SLIDING DOOR L/H	10.6	4.8 (13	
SLIDING DOOR R/H	10.6	4.8 (13	
<b>ENVIRONMENT</b>			
AIR CONDITIONER (SINGLE FORWARD EVAPORATORS)	95.4	43.3 (4, 15	
AIR CONDITIONER (DUAL FORWARD EVAPORATORS)	105.6	47.9 (4, 15	
BLEED AIR HEATER W/ CHIN BUBBLE DEFROSTER	22.6	10.3 (10	
BLEED AIR ARCTICHEATER W/ CHIN BUBBLE DEFROST	23.6	10.7 (10	
ENGINE BLEED AIR NETWORK	3.8	1.7 (10	
FORCED AIR VENTILATION	28.4	12.9 (15	
<b>EQUIPMENT</b>			
PARAVION BLADE FOLDING KIT W/2 EXPANDABLE BOLTS	1.8	0.8 (16	
WIRE STRIKE - RECOMMENDED KIT - SEE NOTE 17	12.1	5.5 (17	
<b>INTERIOR</b>			
FLOOR PROTECTOR (CREW AND PASSENGER)	8.3	3.8	
FLOOR PROTECTOR (BAGGAGE)	5.3	2.4	
SPACE MAKER	6.0	2.7	



## ***Optional Accessories [EXPLANATORY NOTES] (continued)***

• • • • • REFER TO NOTES FOR KIT COMPATIBILITY • • • • •

### **All equipment kits require Provision Kits prior to installation**

**Notes: For commonality, notes shown below are identical in Product Specification and Price List.**

- (1) Price and / or Weight includes credit for basic ship hardware removed.
- (2) Kit includes Flitesteps (STC # 407-326-003) [weight; 28 lbs (12.7 kgs)].
- (3) Kit includes Floatsteps (STC # 407-303-003) [weight; 29 lbs(13 kgs)].
- (4) When ANY Airconditioner Kit is installed, and VHF and/or ADF are installed, the antennas must be relocated.
- (5) Encoding Altimeter or Blind Encoder (customizing) is required to enable Mode C/Mode S altitude reporting and/or GPS altitude input. Customer must obtain Aircraft ID code for Mode S.
- (6) One Geographic Database must be selected and installed concurrently with GPS Equipment KLN-89B.
- (7) When ANY Compass System KCS-55A is installed the Directional Gyro is **NOT** required.
- (8) For GPS compatible KCS-55A to function, GPS Provisions & Equipment must be installed.
- (9) Requires installation of VHF/ADF Prov. and VHF/eqpt.; Flight Inst.; ELT; and Engine Fire Det.
- (10) Particle separator and Bleed Air Heaters both include Bleed Air Network. If both kits are installed subtract 3.8 lb(1
- (11) Requires installation of -159 Litter provisions.
- (12) Corporate interior **requires** corporate soundproofing and corporate arm rests.
- (13) Sliding door(s) **require** sliding door arm rest(s) 407-705-605-105 which subtracts 1.9 lb (0.9kg) per door.
- (14) Standard or High Visibility Main Rotor Blade Paint to be specified by Sales Order.
- (15) Requires Standard Headliner with A/C ducts (407-705-604-105), weight 4.0 lb(1.8kg).
- (16) Weight is for provisions only.
- (17) For High Skids or floats, weight is 12.7 lb(5.8kg). The Wire Strike Kit is a RECOMMENDED **extra cost** option. The customer must specify on the Purchase Agreement for the WSPS Kit NOT to be installed.
- (18) Complete Emergency Popout Floats Kit requires Landing Gear, Flotation, and Reservoir Kits. **[242 lbs (109.8 kg)**

**STC Kits** - Select Supplemental Type Certificated Optional Equipment Kits are available for installation at the Bell Helicopter Textron factory. Please contact your Bell Sales Representative for availability and pricing information.

**P.O.R.** - Priced On Request.



INTENTIONALLY LEFT BLANK



**HELICOPTER PERFORMANCE**  
**IGE & OGE HOVER, SERVICE CEILING**  
**ROLLS-ROYCE 250-C47B ENGINE**  
**BASIC INLET INSTALLED**  
**MINIMUM SPEC. ENGINE**



**IGE HOVER CEILING  
ROLLS-ROYCE 250-C47B ENGINE AT TAKEOFF POWER  
BASIC INLET INSTALLED**

GROSS WEIGHT - 100 KG

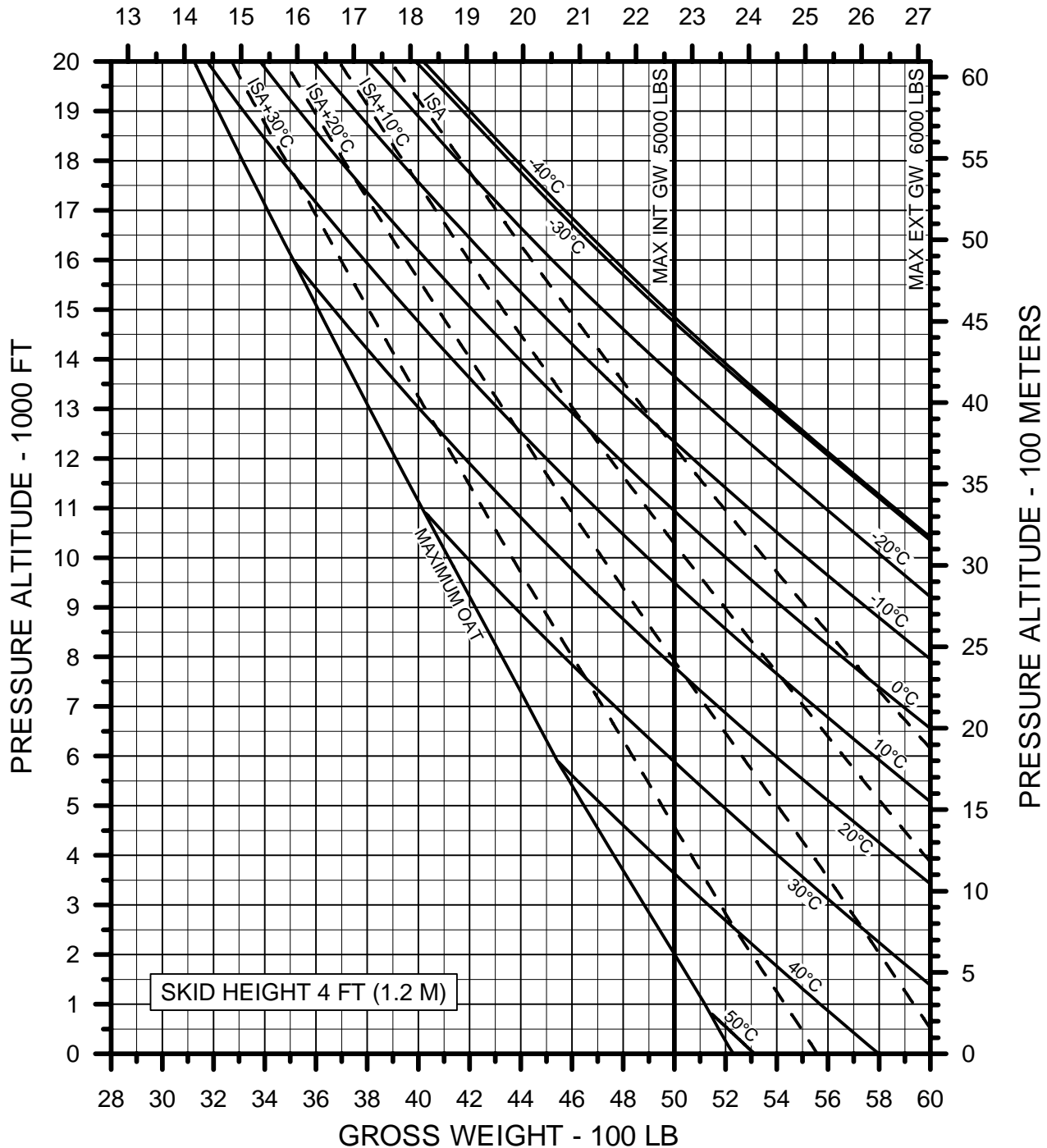

**NOTE: TAKEOFF AND LANDING HAS NOT BEEN DEMONSTRATED AND IS NOT APPROVED ABOVE 17,000 FEET / 5182 METERS DENSITY ALTITUDE.**

THE DATA SET FORTH ON THIS DOCUMENT ARE GENERAL IN NATURE AND MAY VARY WITH CONDITIONS. FOR PERFORMANCE DATA AND OPERATING LIMITATIONS FOR ANY SPECIFIC FLIGHT MISSION, REFERENCE MUST BE MADE TO THE APPROVED FLIGHT MANUAL.



**OGE HOVER CEILING**  
**ROLLS-ROYCE 250-C47B ENGINE AT TAKEOFF POWER**  
**BASIC INLET INSTALLED**

GROSS WEIGHT - 100 KG

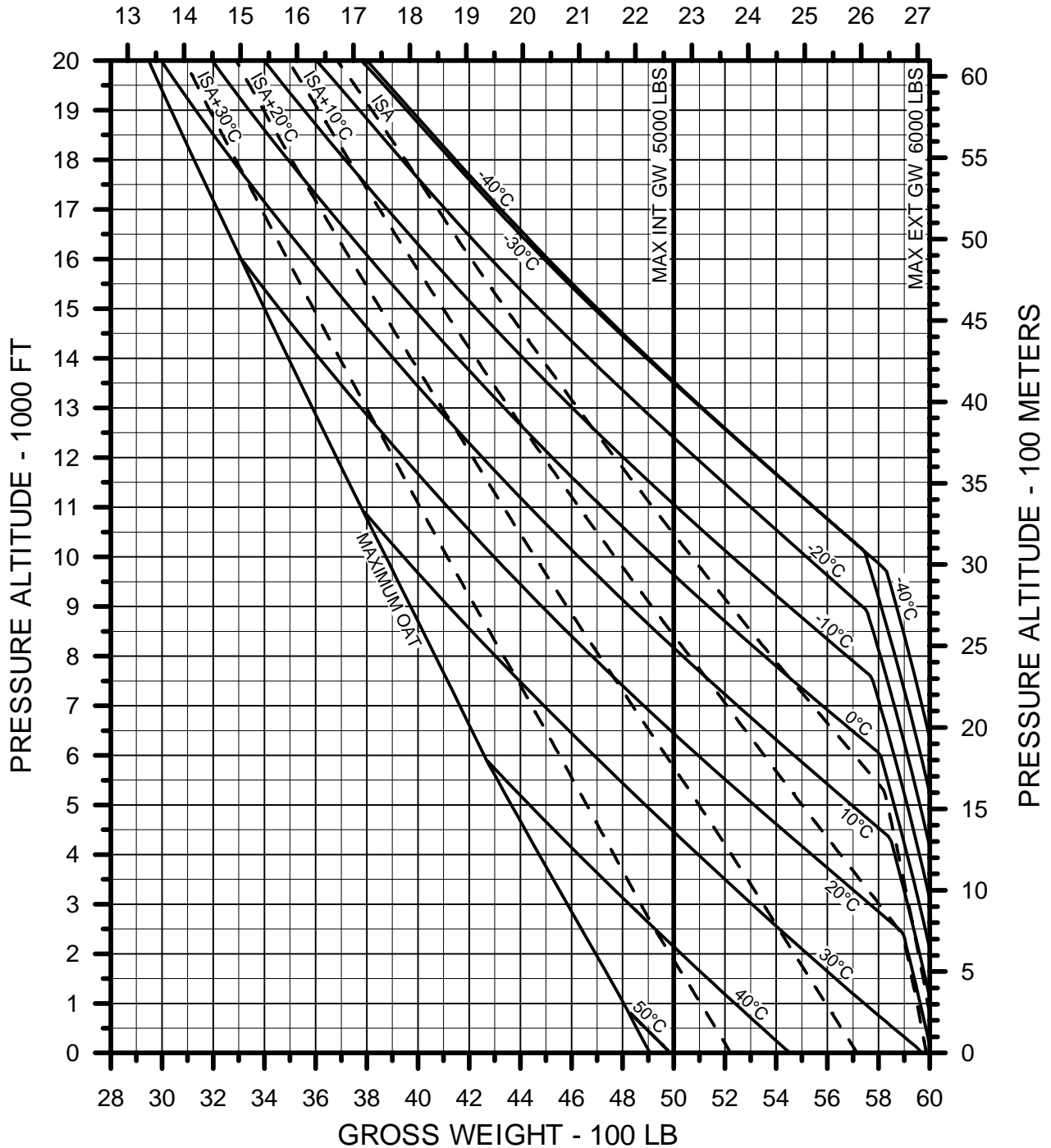

**NOTE:** TAKEOFF AND LANDING HAS NOT BEEN DEMONSTRATED AND IS NOT APPROVED ABOVE 17,000 FEET / 5182 METERS **DENSITY ALTITUDE**.

THE DATA SET FORTH ON THIS DOCUMENT ARE GENERAL IN NATURE AND MAY VARY WITH CONDITIONS. FOR PERFORMANCE DATA AND OPERATING LIMITATIONS FOR ANY SPECIFIC FLIGHT MISSION, REFERENCE MUST BE MADE TO THE APPROVED FLIGHT MANUAL.



**SERVICE CEILING**  
**ROLLS-ROYCE 250-C47B ENGINE AT MAXIMUM CONTINUOUS POWER**  
**BASIC INLET INSTALLED**

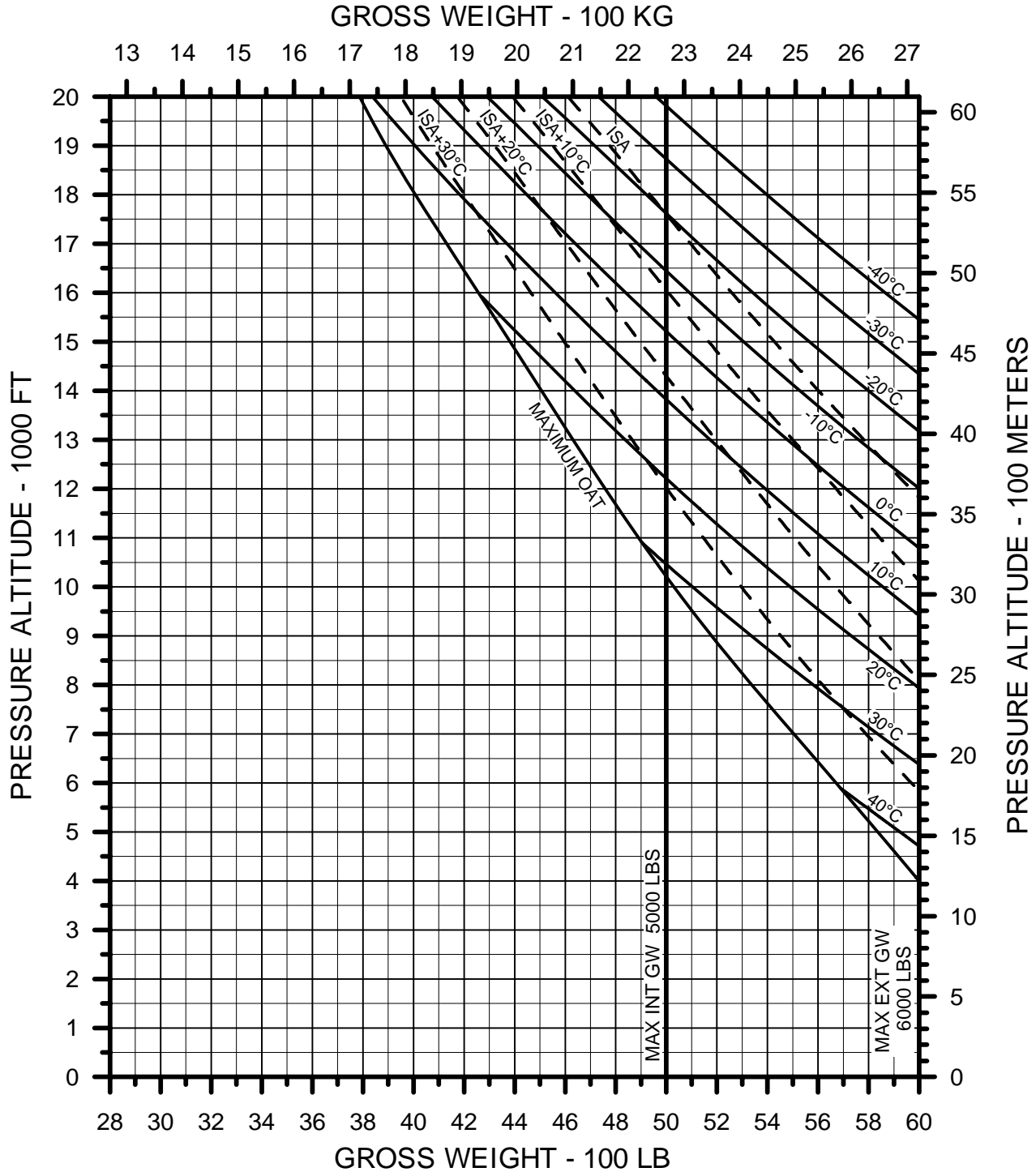

THE DATA SET FORTH ON THIS DOCUMENT ARE GENERAL IN NATURE AND MAY VARY WITH CONDITIONS. FOR PERFORMANCE DATA AND OPERATING LIMITATIONS FOR ANY SPECIFIC FLIGHT MISSION, REFERENCE MUST BE MADE TO THE APPROVED FLIGHT MANUAL.



**TAKE OFF & LANDING LIMITATION  
 OPTIONAL 5250 LB / 2381 KG INTERNAL GROSS WEIGHT KIT  
 ROLLS-ROYCE 250-C47B ENGINE AT TAKEOFF POWER  
 BASIC INLET INSTALLED**

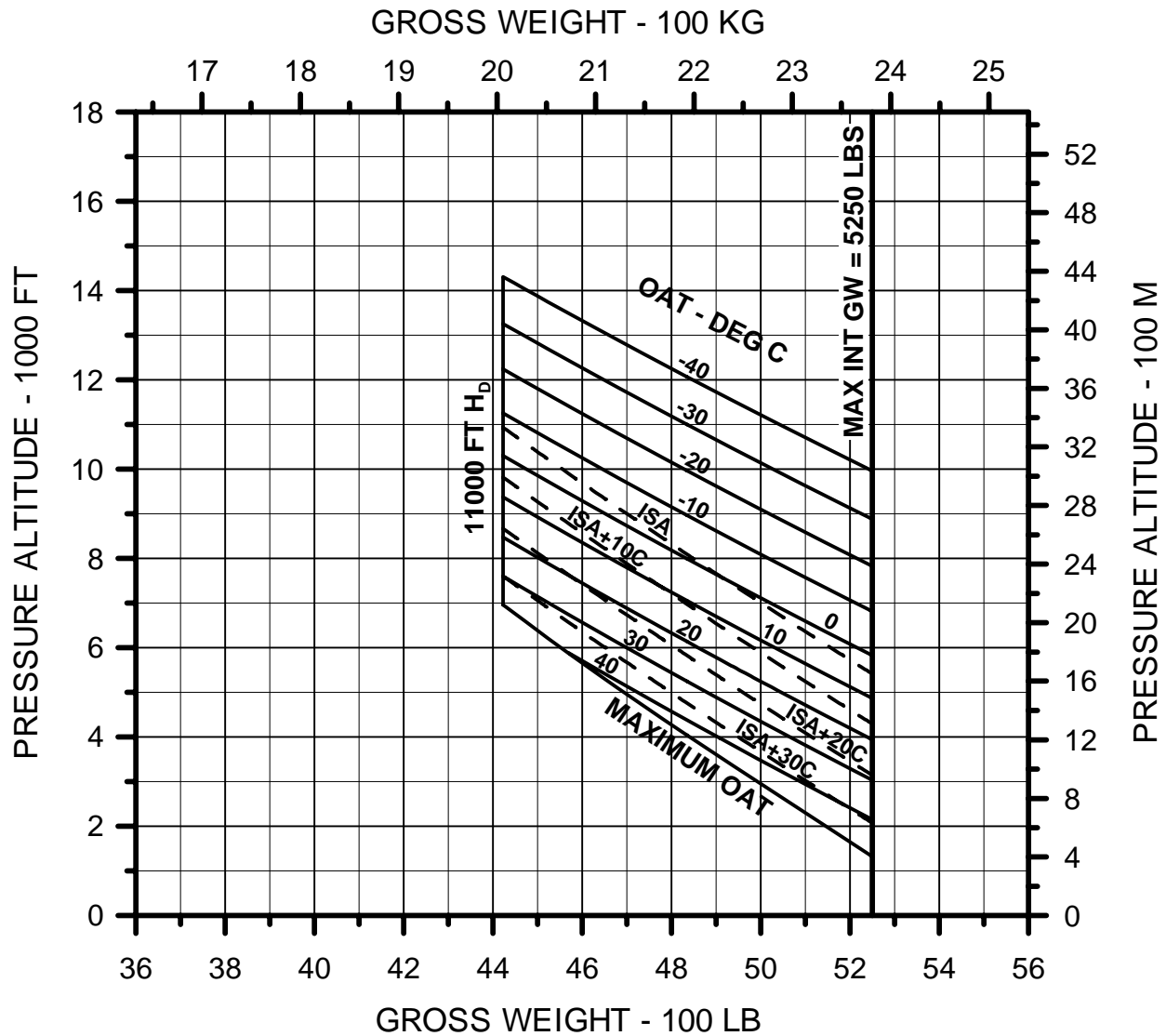

**NOTE:** TAKEOFF AND LANDING WITH OPTIONAL 5250 LB / 2381 KG INTERNAL GROSS WEIGHT HAS NOT BEEN DEMONSTRATED AND IS NOT APPROVED ABOVE 11,000 FEET / 3353 METERS DENSITY ALTITUDE.

THE DATA SET FORTH ON THIS DOCUMENT ARE GENERAL IN NATURE AND MAY VARY WITH CONDITIONS. FOR PERFORMANCE DATA AND OPERATING LIMITATIONS FOR ANY SPECIFIC FLIGHT MISSION, REFERENCE MUST BE MADE TO THE APPROVED FLIGHT MANUAL.



INTENTIONALLY LEFT BLANK



**FUEL FLOW vs AIRSPEED**  
**ISA & ISA+20° C**  
**ROLLS-ROYCE 250-C47B ENGINE**  
**BASIC INLET INSTALLED**  
**LOW SKID GEAR WITHOUT FAIRINGS**  
**with PLUS ENGINE DATA\***

**FOR PARTICLE SEPARATOR INSTALLED;  
INCREASE FUEL FLOW TWO(2)LB/HR[ONE(1)KG/HR]  
FOR CROSS TUBE FAIRINGS;  
INCREASE AIRSPEED THREE(3)KNOTS[FIVE(5)KM/HR]**

**NOTES:**

**THE BEST ALLOWABLE CRUISE SPEED IS EITHER LONG RANGE CRUISE SPEED [LRC], OR WHEN SPEED IS LIMITED BY MAXIMUM CONTINUOUS CRUISE POWER [MCP] OR  $V_{NE}$ , THE MAXIMUM SPEED PERMITTED.**

**\* PLUS ENGINE DATA IS SHOWN WHERE THERE IS A SIGNIFICANT DIFFERENCE BETWEEN MINIMUM SPECIFICATION ENGINE POWER (A "ZERO" ENGINE) AND EITHER MAXIMUM CONTINUOUS POWER OR THE ENGINE MECHANICAL POWER LIMIT. THIS DATA IS PROVIDED TO ASSIST PLANNING OF OPERATIONS WHERE FAST CRUISE SPEED IS DESIRED, BUT THE CONTINUOUS OPERATION LIMITS OF 93.5% TORQUE AND / OR 727 °C ENGINE MGT ARE OBSERVED. THE MAXIMUM ATTAINABLE FAST CRUISE SPEED WILL BE DETERMINED BY SPECIFIC ENGINE HEALTH (POWER ASSURANCE), AND OPERATIONAL LIMIT (TORQUE, MGT, NG, OR  $V_{NE}$ , WHICHEVER OCCURS FIRST).**

**PLUS ENGINE PERCENT CAN BE DETERMINED DURING THE ENGINE POWER ASSURANCE CHECK BY SETTING THE MGT AND RECORDING TORQUE. THE DIFFERENCE BETWEEN THE RECORDED TORQUE AND THE MINIMUM CHART VALUE IS THE PLUS PERCENT FACTOR.**



**FUEL FLOW vs AIRSPEED**  
**PRESSURE ALTITUDE = SEA LEVEL**  
**OAT = +15° C**

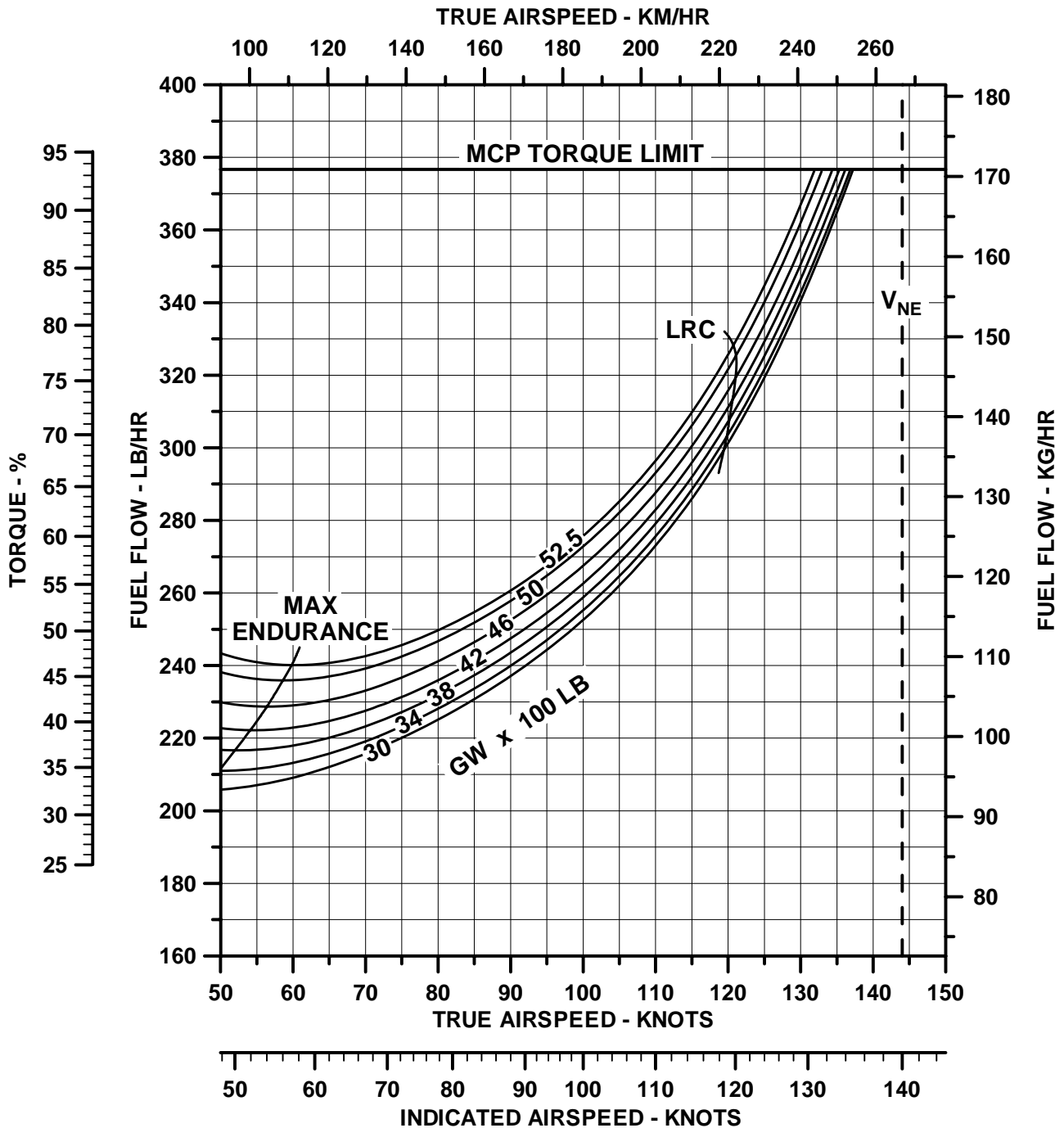

THE DATA SET FORTH ON THIS DOCUMENT ARE GENERAL IN NATURE AND MAY VARY WITH CONDITIONS. FOR PERFORMANCE DATA AND OPERATING LIMITATIONS FOR ANY SPECIFIC FLIGHT MISSION, REFERENCE MUST BE MADE TO THE APPROVED FLIGHT MANUAL.



**FUEL FLOW vs AIRSPEED**  
**PRESSURE ALTITUDE = 2000 FT**  
**OAT = +11° C**

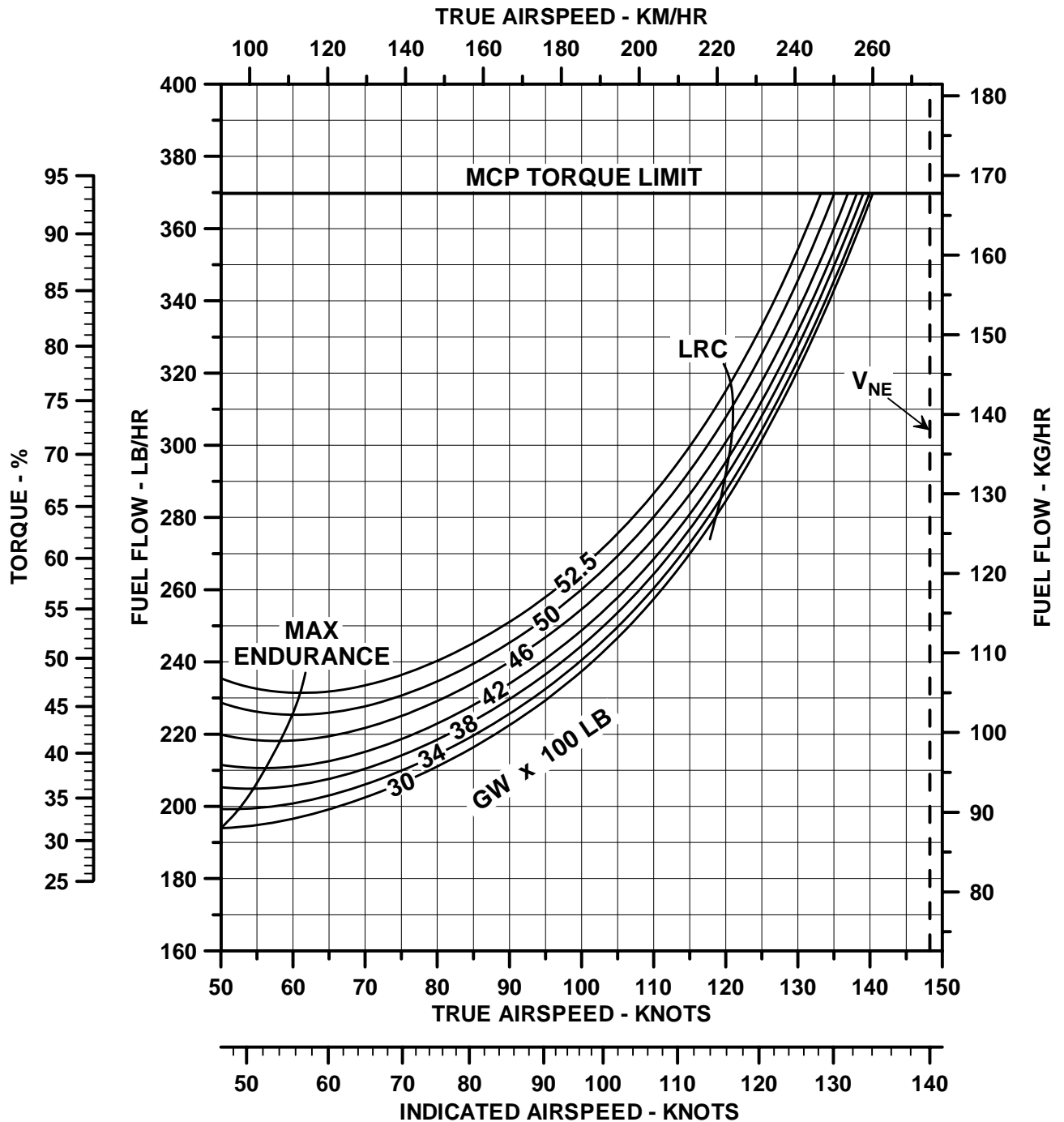

THE DATA SET FORTH ON THIS DOCUMENT ARE GENERAL IN NATURE AND MAY VARY WITH CONDITIONS. FOR PERFORMANCE DATA AND OPERATING LIMITATIONS FOR ANY SPECIFIC FLIGHT MISSION, REFERENCE MUST BE MADE TO THE APPROVED FLIGHT MANUAL.



**FUEL FLOW vs AIRSPEED**  
**PRESSURE ALTITUDE = 4000 FT**  
**OAT = +7° C**

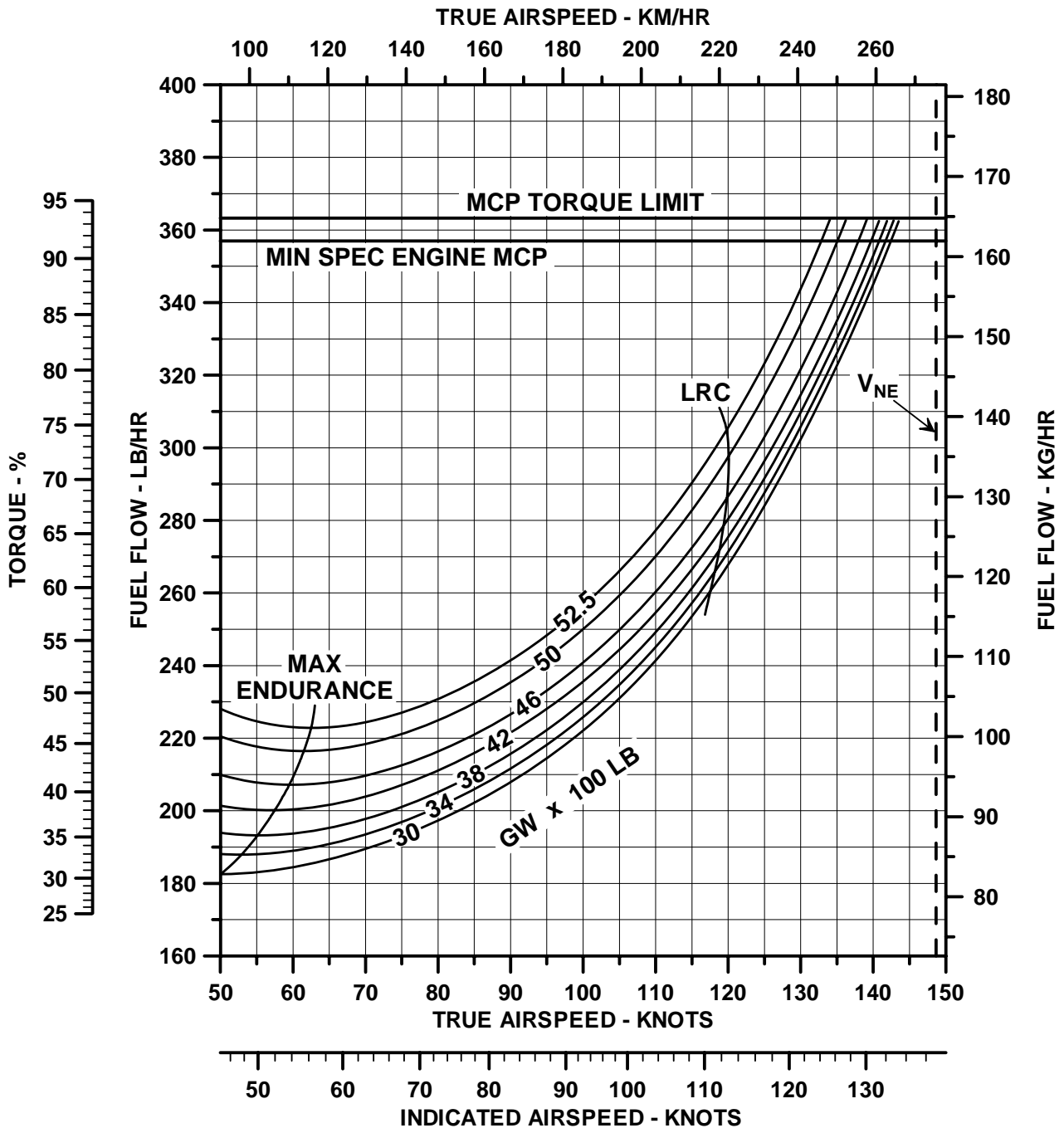

THE DATA SET FORTH ON THIS DOCUMENT ARE GENERAL IN NATURE AND MAY VARY WITH CONDITIONS. FOR PERFORMANCE DATA AND OPERATING LIMITATIONS FOR ANY SPECIFIC FLIGHT MISSION, REFERENCE MUST BE MADE TO THE APPROVED FLIGHT MANUAL.



**FUEL FLOW vs AIRSPEED**  
**PRESSURE ALTITUDE = 6000 FT**  
**OAT = +3°C**

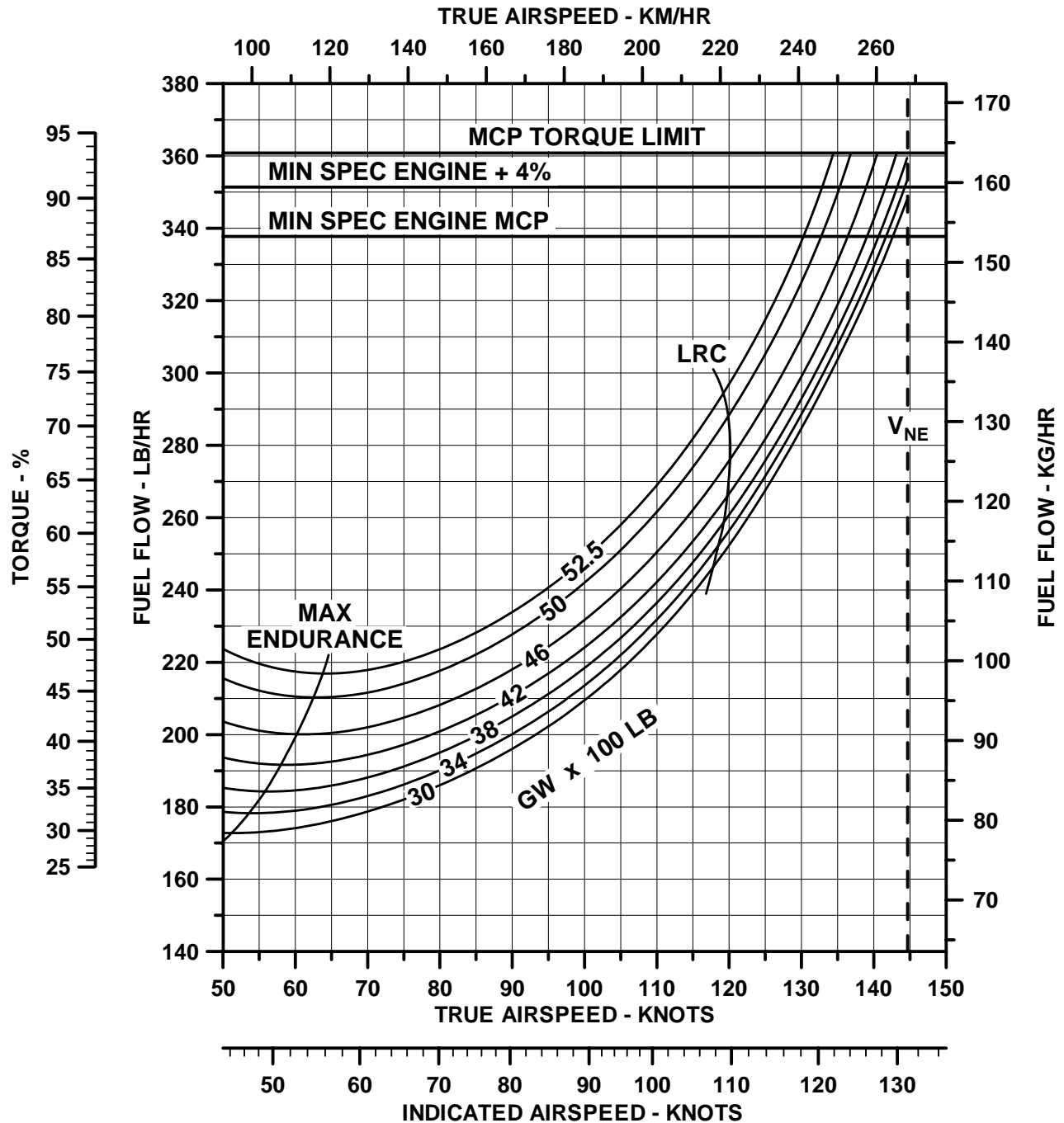

THE DATA SET FORTH ON THIS DOCUMENT ARE GENERAL IN NATURE AND MAY VARY WITH CONDITIONS. FOR PERFORMANCE DATA AND OPERATING LIMITATIONS FOR ANY SPECIFIC FLIGHT MISSION, REFERENCE MUST BE MADE TO THE APPROVED FLIGHT MANUAL.



**FUEL FLOW vs AIRSPEED**  
**PRESSURE ALTITUDE = 8000 FT**  
**OAT = -1°C**

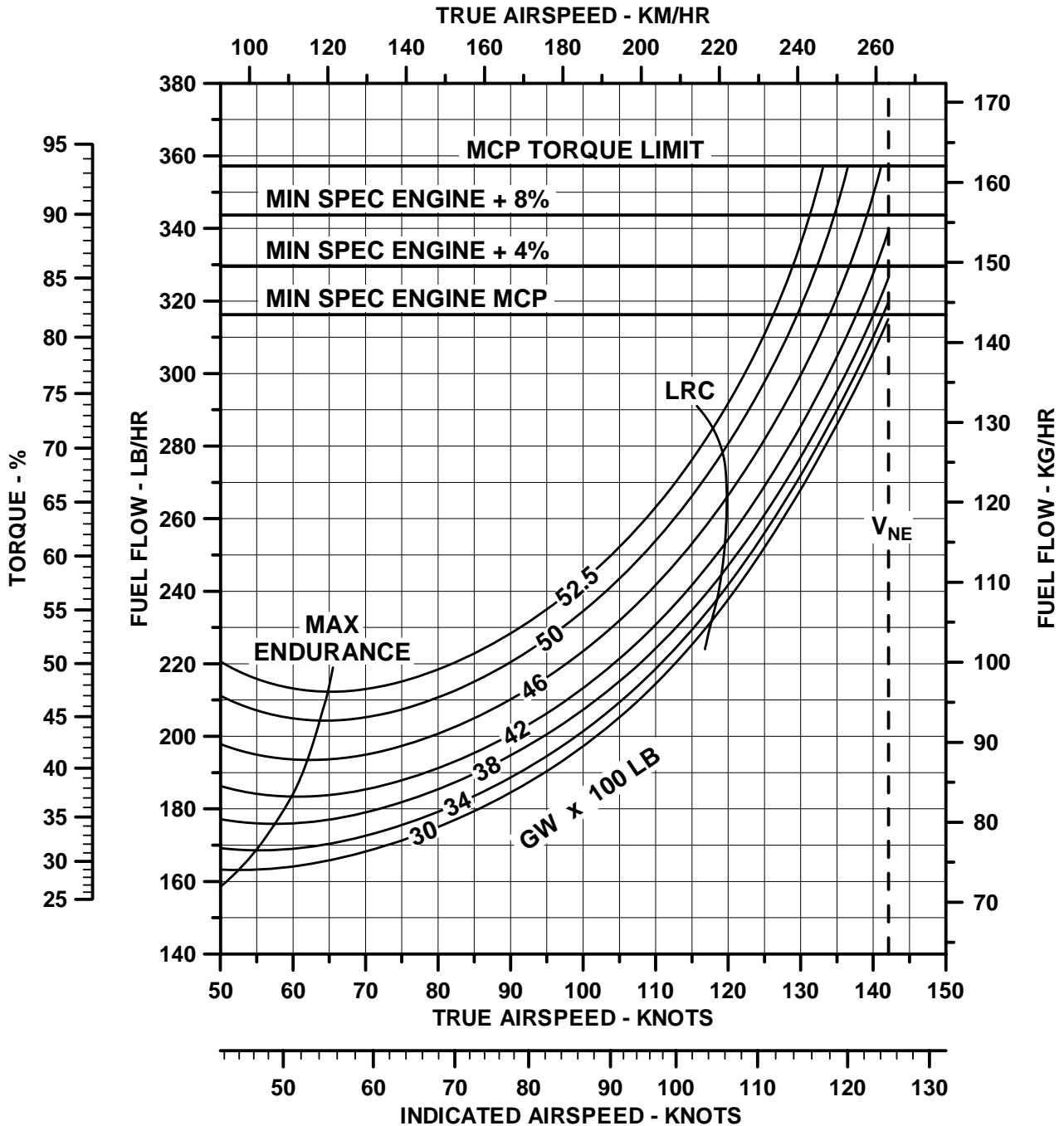

THE DATA SET FORTH ON THIS DOCUMENT ARE GENERAL IN NATURE AND MAY VARY WITH CONDITIONS. FOR PERFORMANCE DATA AND OPERATING LIMITATIONS FOR ANY SPECIFIC FLIGHT MISSION, REFERENCE MUST BE MADE TO THE APPROVED FLIGHT MANUAL.



**FUEL FLOW vs AIRSPEED**  
**PRESSURE ALTITUDE = SEA LEVEL**  
**OAT = +35° C**

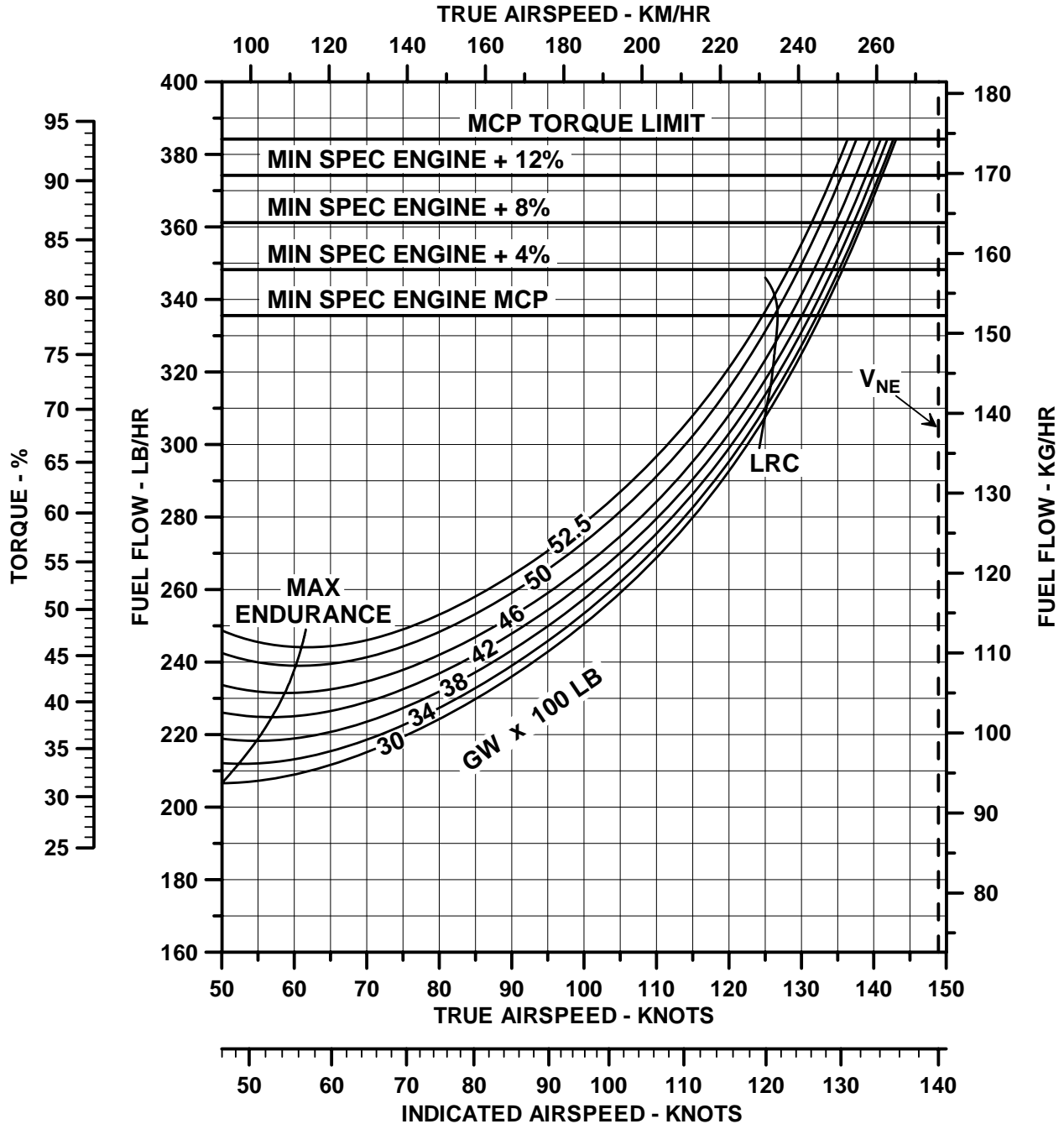

THE DATA SET FORTH ON THIS DOCUMENT ARE GENERAL IN NATURE AND MAY VARY WITH CONDITIONS. FOR PERFORMANCE DATA AND OPERATING LIMITATIONS FOR ANY SPECIFIC FLIGHT MISSION, REFERENCE MUST BE MADE TO THE APPROVED FLIGHT MANUAL.



**FUEL FLOW vs AIRSPEED**  
**PRESSURE ALTITUDE = 2000 FT**  
**OAT = +31° C**

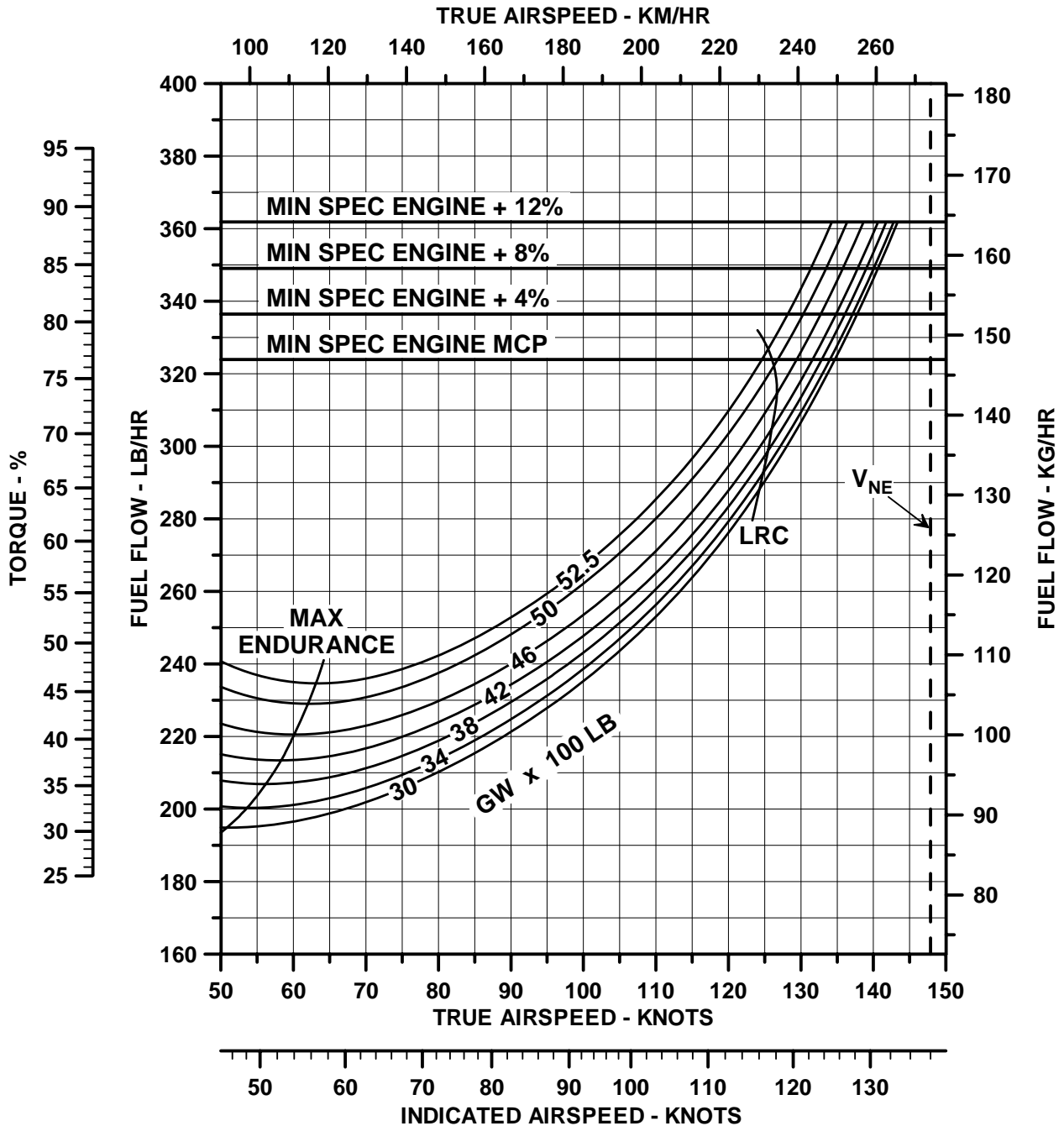

THE DATA SET FORTH ON THIS DOCUMENT ARE GENERAL IN NATURE AND MAY VARY WITH CONDITIONS. FOR PERFORMANCE DATA AND OPERATING LIMITATIONS FOR ANY SPECIFIC FLIGHT MISSION, REFERENCE MUST BE MADE TO THE APPROVED FLIGHT MANUAL.



**FUEL FLOW vs AIRSPEED**  
**PRESSURE ALTITUDE = 4000 FT**  
**OAT = +27° C**

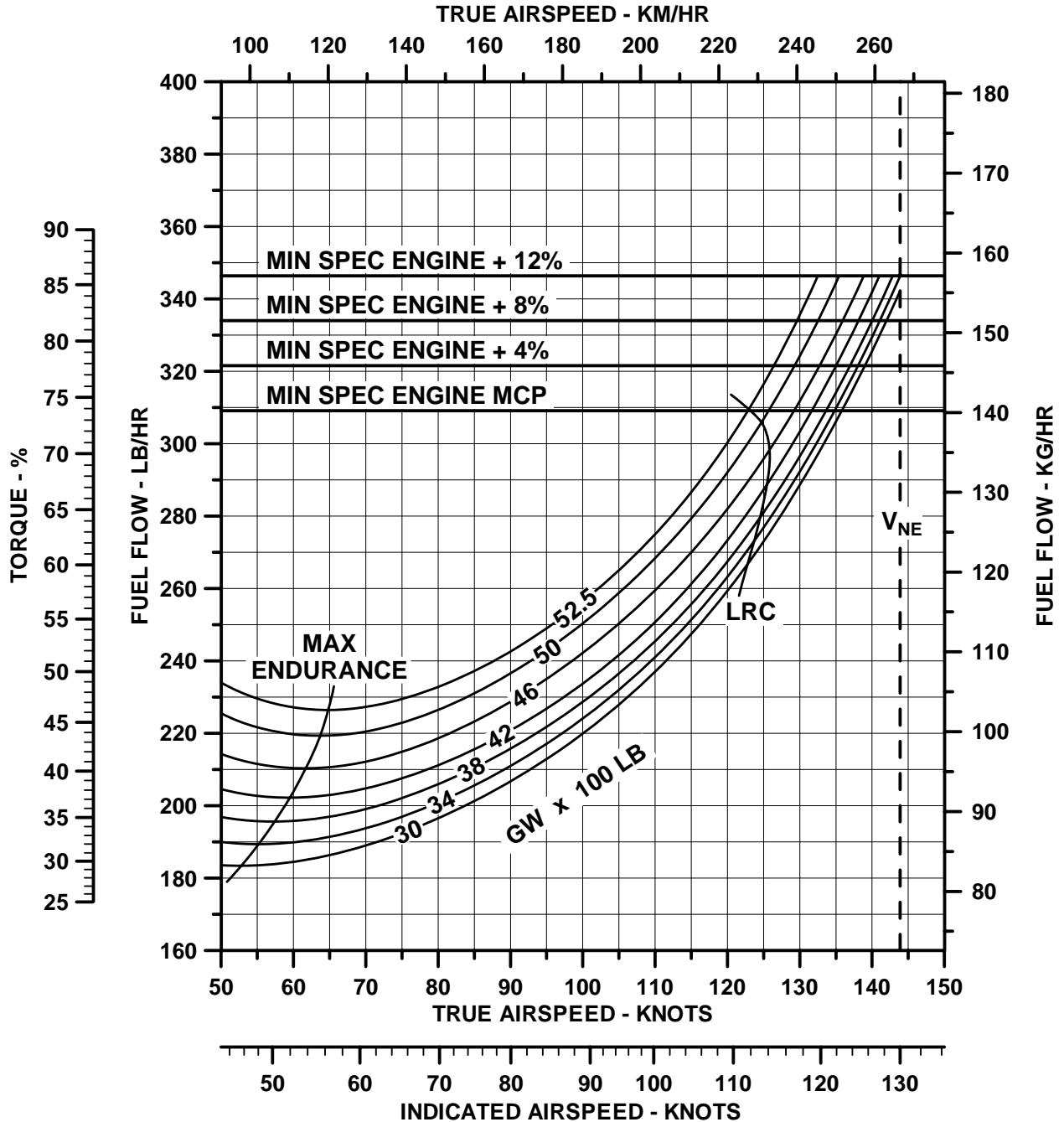

THE DATA SET FORTH ON THIS DOCUMENT ARE GENERAL IN NATURE AND MAY VARY WITH CONDITIONS. FOR PERFORMANCE DATA AND OPERATING LIMITATIONS FOR ANY SPECIFIC FLIGHT MISSION, REFERENCE MUST BE MADE TO THE APPROVED FLIGHT MANUAL.



**FUEL FLOW vs AIRSPEED**  
**PRESSURE ALTITUDE = 6000 FT**  
**OAT = +23° C**

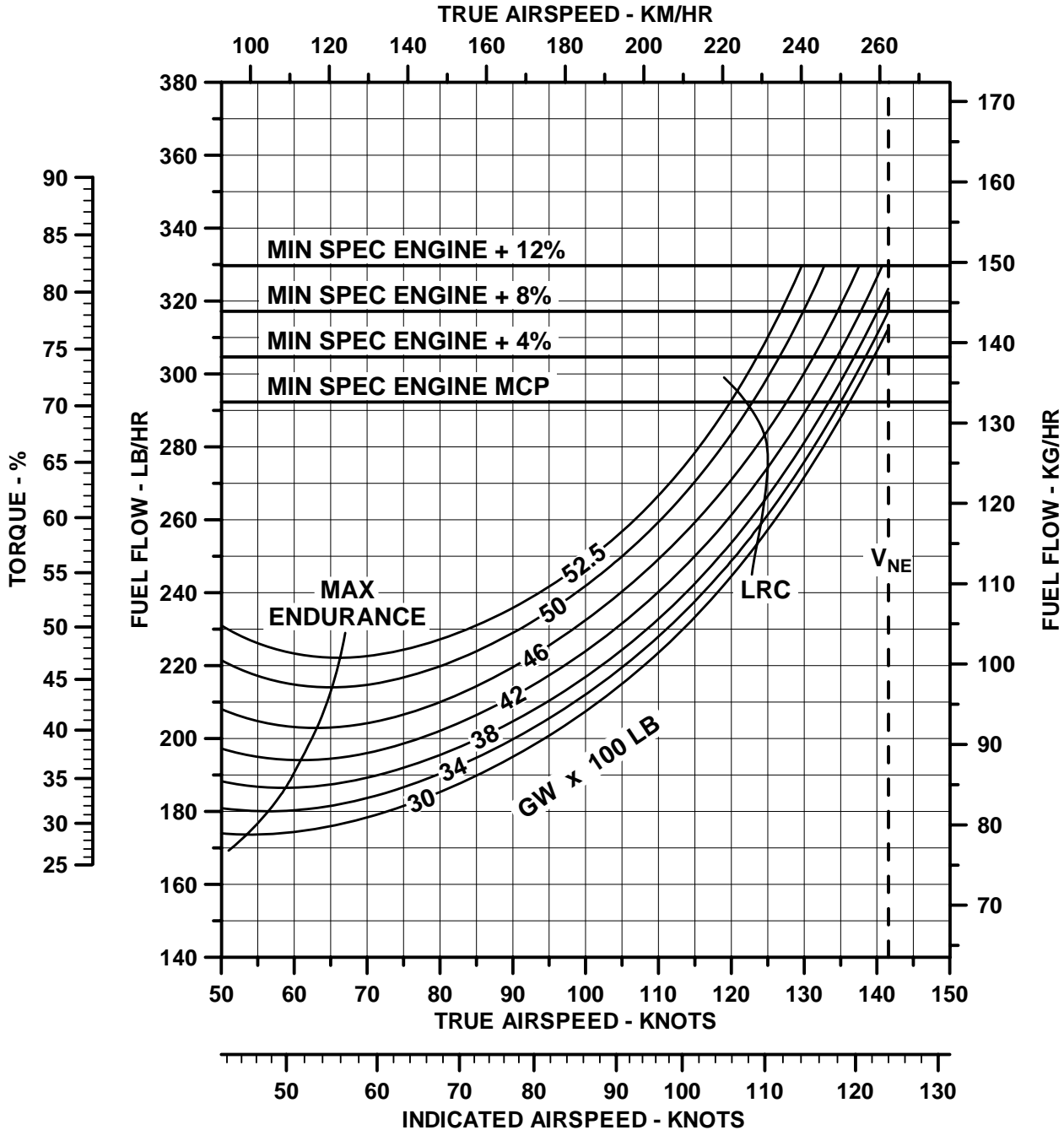

THE DATA SET FORTH ON THIS DOCUMENT ARE GENERAL IN NATURE AND MAY VARY WITH CONDITIONS. FOR PERFORMANCE DATA AND OPERATING LIMITATIONS FOR ANY SPECIFIC FLIGHT MISSION, REFERENCE MUST BE MADE TO THE APPROVED FLIGHT MANUAL.



**FUEL FLOW vs AIRSPEED**  
**PRESSURE ALTITUDE = 8000 FT**  
**OAT = +19° C**

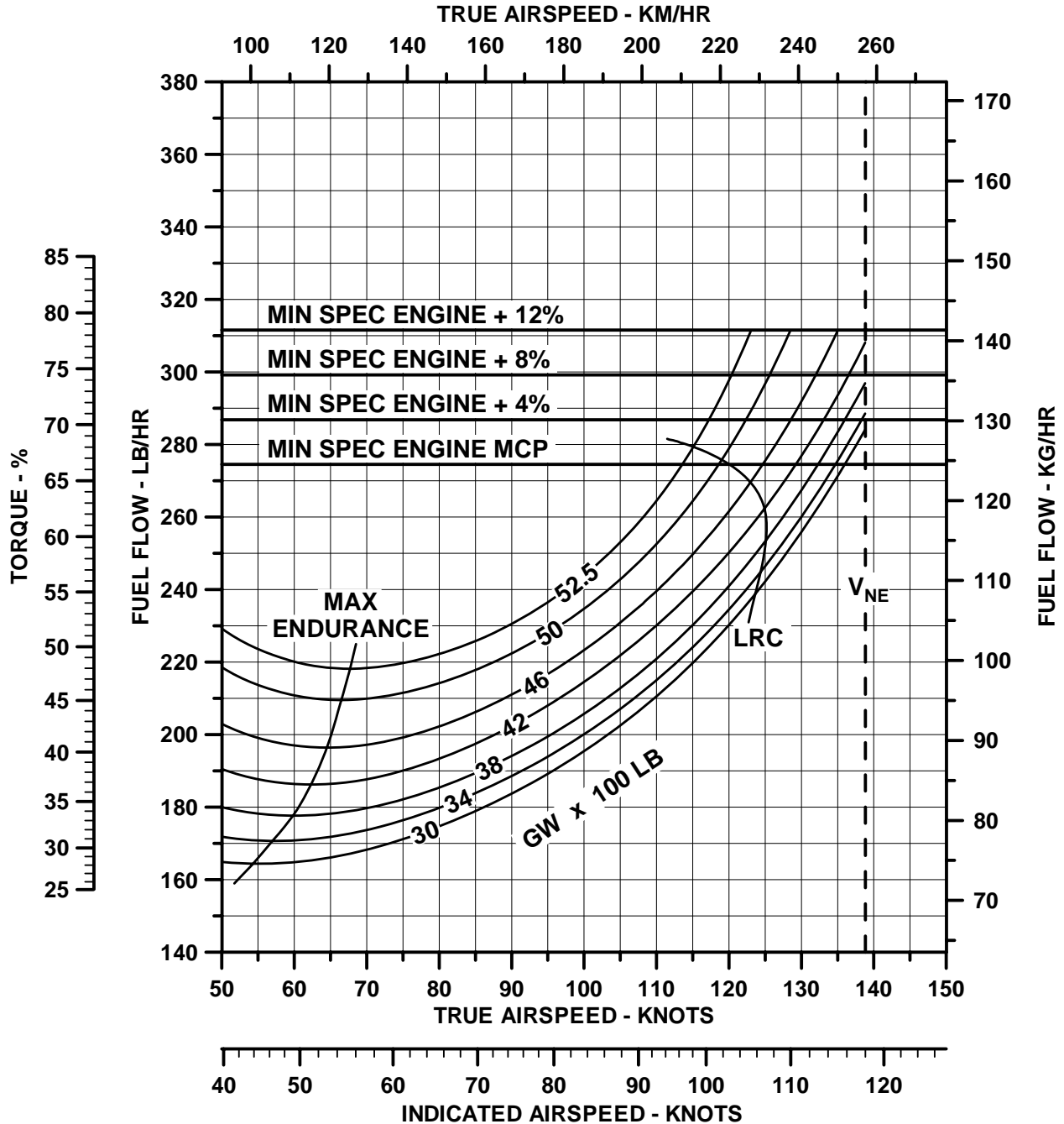

THE DATA SET FORTH ON THIS DOCUMENT ARE GENERAL IN NATURE AND MAY VARY WITH CONDITIONS. FOR PERFORMANCE DATA AND OPERATING LIMITATIONS FOR ANY SPECIFIC FLIGHT MISSION, REFERENCE MUST BE MADE TO THE APPROVED FLIGHT MANUAL.



## **COST OF OPERATIONS**

### **INTRODUCTION**

Bell Helicopter Textron's cost of operations data for current production helicopters is based on information from Bell operators and service facilities.

BHT's Product Support organization accumulates cost data from a diverse group of operators - large, small; sub-polar, subtropical; inland, coastal; corporate, charter. This information is analyzed to generate sample data for each production model which are averages of the field experience.

BHT intends to continue monitoring actual costs to enable annual updates of the data to maintain its currency.

The following discussion is provided to review the variables involved in the helicopter's direct and indirect cost of operations as well as its cost of ownership.

The total cost of helicopter ownership and operation involves both direct and indirect costs. The direct costs are those which are incurred essentially by the flight hour and include:

- Fuel, Lubricants
- Basic Airframe Maintenance
- Powerplant Maintenance

The indirect costs are not directly dependent upon the number of hours flown and include:

- Insurance
- Facilities (hangar, workshop, etc.)
- Crew Compensation
- Financial Factors (depreciation, investment tax credit, financing costs, etc.)

Sample direct operating cost data is available for each current production model. Detailed estimates for total costs relating to specific operations are available through the BHT regional marketing manager or corporate office using input data supplied by customer/prospect.

### **DIRECT COSTS**

#### **Fuel, Lubricants**

A typical average value of fuel and lubricant costs is included in the sample data provided for each model.

Fuel consumption depends upon speed, temperature, externally-mounted accessories, sling loads, etc. A band of approximately 10% more or less than sample value will cover these factors for normal operations.

Fuel pricing varies considerably based on where the fuel is purchased geographically and whether it is purchased retail or in bulk. The sample cases use average retail purchase price prevalent at the time of the sample data are prepared.

#### **Basic Airframe Maintenance**

Airframe maintenance is divided into four categories:

- Periodic Inspections
- Overhauls
- Replacement of Retirement Parts
- Unscheduled

Periodic inspections include those inspection tasks, with their part requirements, listed in the Maintenance Manual for each model.

Man hours for periodic inspections can vary from the sample value provided because of differences in personal experience, tool and parts availability, facilities, environmental effects such as extremes in working temperatures. Man hour costs/hour are also variable among the Authorized Service Centers as a result of differences in local costs, overhead expenses and volume of work. The sample value is an average of costs per hour at Authorized Service Centers at the time of publication.

Overhauls include removal, disassembly, inspection, parts replacement, reassembly and reinstallation of certain components/assemblies at the periods stated in the BHT Maintenance Manual.

Overhaul man hour and parts requirements are subject to considerable variation depending upon the helicopter's operations and environments. The sample data reflect average values.



## **COST OF OPERATIONS (continued)**

Retirement parts are those which are subject to disposal after an operating time stated in the Maintenance Manual. These are normally components of the rotors/control systems which are subject to oscillatory loads and are designed and tested for use over a finite number of flight hours rather than on their condition. The replacement at the required intervals requires some labor which is included in the man hour data in the sample.

Unscheduled maintenance encompasses labor and parts replacement for major maintenance not covered under the formal Maintenance Manual requirements for inspections and overhauls. It also includes those additional maintenance requirements imposed by the manufacturer through issue of Service Bulletins.

The sample data for periodic inspections provide for some minor unscheduled maintenance tasks resulting from the inspection.

### **Powerplant Maintenance**

The powerplant (engine [s]) requires periodic inspection and overhauls. The overhaul periods are based on the number of operating hours or on the number of cycles, whichever is the first limit to be attained. Start cycles are a factor because thermal cycles are important in the design of the turbine engine's rotating components. Overhauls are performed by the engine manufacturer and/or at authorized facilities.

Powerplant overhaul can be performed for the engine as a unit, or in some cases for individual modules. (Modules can be gearbox, compressor, turbine, for example.) Each module can have its own overhaul period. Modular overhaul can be cost-effective for some operations and it use should be evaluated.

Engine or module exchanges can be made in lieu of overhaul. For details, contact the engine manufacturer or his authorized distributors/service centers. The sample costs are based on an average exchange.

The powerplant may also require unscheduled maintenance (unscheduled removals for repair, parts replacement).

### **INDIRECT COSTS**

#### **Insurance**

Insurance rates are based on a number of factors including claim experience, type of operations, and crew qualifications. Rates can be obtained from insurance agent/broker.

#### **Facilities**

Facilities can include hangar, workshop, parts storage area, tools, ground support equipment and administrative area as appropriate to the specific operation.

#### **Crew Compensation**

The number of aircrew personnel depends on the individual operation; i. e., whether the normal crew consists of one or two pilots, hours per day flown, backup requirements for illness, vacation, etc.

Bell regional marketing managers can advise typical local costs for estimation purposes.

#### **Financial Factors**

Funding a helicopter purchase can be accomplished in a variety of ways, including cash, short term note, long term note, partnership, etc. For investment accounting, several depreciation methods also exist; straight line, double declining, sum of the years digits, etc. Value of resale is a significant factor.

#### **Miscellaneous Factors**

Staff expenses (other than aircrew and direct maintenance personnel), utilities, office expenses, etc.

### **OWNERSHIP ANALYSIS PROGRAM**

Bell Helicopter Textron uses the **Life Cycle Cost 2006** computer program provided by **Conklin & de Decker Associates, Inc.** to determine ownership costs for an operators planned period of utilization for the aircraft. Conklin's Rotorcraft Analysis Office may be contacted at: Phone; (817)277-6403 or Fax; (817)277-6402.

Bell's regional marketing managers or corporate office personnel will be able to assist in preparing an ownership analysis which is customized for our customers specific individual conditions and needs.



**SAMPLE - DIRECT COST OF OPERATIONS  
US DOLLARS PER FLIGHT HOUR**

**OPERATOR  
OVERHAUL**

**Fuel, Lubricants**

Fuel: (Note 1) [46 gallons per hour]	\$103.50
Lubricants: 3% of Fuel Cost	3.11

**Airframe Direct Maintenance**

**Labor:** (Note 2)

Inspection	(0.165 MH/FH)	10.73
Overhaul	(0.126 MH/FH)	8.21
Unscheduled and On-Condition	(0.832 MH/FH)	54.10

**Parts:**

Inspections	3.26
Retirement	59.23
Overhaul	48.36
Unscheduled and On-Condition	69.75

**Powerplant Direct Maintenance**

Overhaul (Including Accessories)	69.12
Line Maintenance (Labor)	(0.067 MH/FH) 4.33

**Total Average Cost Per Hour** **\$431.70**

**Note 1:** Fuel at \$2.25 per gallon. Average fuel consumption for LRC at 1000 feet, ISA, ( Jet-A at 6.8 Lb/Gal.)

**Note 2:** Labor rate assumed at \$65.00 per hour.

**Note 3:** Includes all scheduled and unscheduled maintenance and life limited parts replacement assuming normal operating environment.

**COMPONENT OVERHAUL INTERVALS (HOURS)**

M/R Hub	2,500	Swashplate	2,500	K-Flex Drive Shaft	2,500
Mast Assy	2,500	T/R Gearbox	3,500	Rotor Brake	5,000
Transmission	3,500	T/R Hub	2,500	Starter Generator	1,000
		Freewheeling Assy	2,500		

**COMPONENT OVERHAUL NOTE:** Analysis of Lead - the - Fleet performance data continues to permit extension of TBO's beyond 2500 hours for drive train components.



### LIMITED LIFE COMPONENTS

<u>PART NUMBER</u>	<u>COMPONENT</u>	<u>LIFE LIMIT (HOURS)</u>	<u>QTY PER A/C</u>	<u>LIST PRICE (EA)</u>	<u>TOTAL COST (FLT HR)</u>
<b><u>MAIN ROTOR HUB AND BLADES</u></b>					
406-010-108-131	Main Rotor Grip	5,000	4	7,785.00	\$6.23
407-010-103-113	Pitch Horn	5,000	4	4,374.00	\$3.50
406-010-115-119	Main Rotor Upper Plate	2,500	1	5,906.00	\$2.36
406-010-117-115	Main Rotor Lower Plate	2,500	1	4,732.00	\$1.89
407-010-107-103	Lower Cone Seat	10,000	1	5,320.00	\$0.53
406-010-126-107	Drive Ring Set	48000 RIN	1	8,538.00	\$0.89
<b><u>MAIN ROTOR CONTROLS</u></b>					
<b><u>SWASHPLATE DRIVE</u></b>					
406-010-413-133	M/R Pitch Link Tube	5000	4	2,097.00	\$1.68
406-010-426-101	Drive Link	5000	2	1,759.00	\$0.70
406-010-425-107	Drive Lever	5000	2	2,569.00	\$1.03
406-010-427-109	Gimbal Ring	5000	1	2,801.00	\$0.56
406-010-428-109	Drive Hub Set	5000	1	2,325.00	\$0.47
406-010-411-117	Swashplate Outer Ring	5000	1	13,158.00	\$2.63
406-010-410-121	Swashplate Inner Ring	5000	1	7,783.00	\$1.56
406-010-416-101	Clevis	5000	4	421.00	\$0.34
406-310-405-101	Bearing	5000	4	2,859.00	\$2.29
<b><u>SWASHPLATE ANTI-DRIVE</u></b>					
406-010-432-101	Anti-Drive Link	5,000	1	2,937.00	\$0.59
406-010-431-109	Anti-Drive Lever	5,000	1	2,008.00	\$0.40
406-010-406-119	Swashplate Support Assembly	5,000	1	7,288.00	\$1.46
406-010-409-107	Swashplate Sleeve Assembly	5,000	1	8,524.00	\$1.70
406-010-408-101	Collective Lever	5,000	1	3,415.00	\$0.68
406-010-407-101	Collective Idler Link	5,000	1	752.00	\$0.15
407-001-524-105	Collective Xmsn Bellcrank	5,000	1	1,715.00	\$0.34
407-001-526-105	Cyclic Longitudinal Bellcrank	5,000	1	1,715.00	\$0.34
407-001-528-105	Cyclic Lateral Xmsn Bellcrank	5,000	1	1,646.00	\$0.33
407-001-511-101	Bell Crank Support	5,000	1	2,965.00	\$0.59
407-001-500-105	Actuator Support Assembly	10,000	1	9,876.00	\$0.99
406-310-404-101	Rod End Bearing Assembly	5,000	1	814.00	\$0.16
<b><u>TAIL ROTOR</u></b>					
406-016-100-119	T/R Blade	5,000	2	15,381.00	\$6.15
406-012-102-109	T/R Yoke	5,000	1	9,439.00	\$1.89
<b><u>DRIVE SYSTEM</u></b>					
407-040-038-111	Main Rotor Mast	18000 RIN	1	22,555.00	\$6.27
206-340-300-105	Input Driveshaft	5,000	1	31,490.00	\$6.30
<b><u>PYLON SUPPORT</u></b>					
407-010-201-105	L/H Pylon Side Beam (1)	5,000	1	6,035.00	\$1.21
407-010-203-105	R/H Pylon Side Beam (1)	5,000	1	5,969.00	\$1.19
407-010-206-103	Pylon Restraint Spring	5,000	2	4,576.00	\$1.83
<b><u>TOTAL</u></b>					<b><u>\$59.23</u></b>

(1) Applies expected life limit of 39,000 RIN & uses a 1/3 rd penalty of that value assuming 5 RIN per hour = 5,000 hour effective life.

**Prices and hours are subject to change without notice.**

THESE DATA ARE PROVIDED FOR ILLUSTRATION PURPOSES. CONSULT MAINTENANCE DOCUMENTS AND BHT SPARE PARTS PRICING FOR CURRENT, OFFICIAL INFORMATION.



**Sample Illustrations of the  
Standard Paint Schemes  
are available from your  
Bell Helicopter Sales Representative**

**PAINT SELECTION NOTES:**

- 1. COLOR RENDERINGS (ORIGINAL) MUST BE PROVIDED FOR ANY DEVIATION TO THE STANDARD SCHEMES (ALL MODELS).**
- 2. CUSTOM PAINT SCHEMES TO CUSTOMER SPECIFICATION ARE AVAILABLE, AND A PRICE QUOTE WILL BE PROVIDED ON REQUEST. PLEASE PROVIDE AS MUCH DETAIL AS POSSIBLE WHEN DESCRIBING SPECIAL INSTRUCTIONS AND CUSTOM PAINT SCHEMES.**
- 3. THE DANGER ARROW IS ALWAYS APPLIED ON THE TAIL BOOM BETWEEN THE HORIZONTAL STABILIZER AND THE TAIL ROTOR, NOT WITHSTANDING ANY OTHER ILLUSTRATIONS.**
- 4. UNLESS CLEARLY SPECIFIED (LOCATION, DIMENSION, COLOR), REGISTRATION MARKINGS WILL BE APPLIED PER FAA REGULATIONS (ALL MODELS).**
- 5. METALLIC PAINT CAN NOT BE APPLIED OVER RADOME AREAS WHEN A RADAR IS INSTALLED.**
- 6. PLACEMENT OF BELL MODEL LOGOS IS EFFECTED BY INDIVIDUAL PAINT SCHEMES, AND WILL BE APPLIED AT THE DISCRETION OF BELL HELICOPTER UNLESS OTHERWISE SPECIFIED BY THE CUSTOMER.**

**For additional information visit the Bell Helicopter Textron Website**

Homepage: [www.bellhelicopter.com](http://www.bellhelicopter.com)

**BELL HELICOPTER TEXTRON INC.**

**Sales Contact Telephone Numbers**

Sales Inquiries

U.S. Toll Free: 1-800-FLY-BELL

International/US: 817-280-2800

Email: [marketing@bellhelicopter.textron.com](mailto:marketing@bellhelicopter.textron.com)

**Regional Sales Areas**

US/Canada 817-280-6789

Asia Pacific 817-280-2197

Europe/Middle East/Africa 817-280-3261

Latin America 817-280-2879

Used Helicopter Sales / [www.BellNetX.com](http://www.BellNetX.com) 817-280-2147

Fax: 817-280-8802

**Customer Center**

**Ft. Worth / Alliance Airport Facility**

P. O. Box 482

Ft. Worth, TX 76101-0482

817-280-6187 Fax: 817-280-8802

[marketing@bellhelicopter.textron.com](mailto:marketing@bellhelicopter.textron.com)

**Manufacturing Facility**

Bell Helicopter Textron Canada Limited

12,800 rue de l'Avenir

Mirabel, Quebec

Canada J7J 1R4

450-437-3400 Fax: 450-437-2006

This book was produced by



Visual Communications Center

P. O. Box 482

Ft. Worth, TX 76101-0482



P.O. Box 482, Fort Worth, Texas 76101,  
Phone: (817) 280-2800, Fax: (817) 278-8802  
[www.bellhelicopter.textron.com](http://www.bellhelicopter.textron.com)

**BELL HELICOPTER TEXTRON CANADA LIMITED**  
12,800 rue de l' Avenir  
Mirabel, Quebec, Canada J7J1R4  
Phone: (450) 437-3400 Fax: (450) 437-2006

The data set forth in this brochure are general in nature and may vary with conditions. For performance data and operating limitations for any specific flight mission reference must be made to the approved flight manual.

Written, Edited and Layout by:  
Dave Wyatt  
817-280-6918  
E-Mail Address: [dwyatt@bellhelicopter.textron.com](mailto:dwyatt@bellhelicopter.textron.com)

© 2006 Bell Helicopter Textron Inc.  
All Rights Reserved.  
Printed in USA  
January 2006